

---

**CHAPTER 7.  
APPENDICES**

**SPECIFICATIONS ..... 7-1**  
    **GENERAL SPECIFICATIONS ..... 7-1**  
    **MAINTENANCE SPECIFICATIONS ..... 7-4**

**GENERAL TORQUE SPECIFICATIONS.. ..... 7-17**

**DEFINITION OF UNITS ..... 7-17**

**LUBRICATION DIAGRAM.. ..... 7-18**

**CABLE ROUTING.. ..... 7-22**

**SRX600S COLOR WIRING DIAGRAM**



## APPENDICES

## SPECIFICATIONS

## GENERAL SPECIFICATIONS

Model	SRX600S
Model Code Number:	2EH
Vehicle Identification Number:	JYA2EH00 * GAO00101
Engine Starting Number:	2EH-000101
Dimensions:	
Overall Length	2,120 mm (83.5 in)
Overall Width	705 mm (27.8 in)
Overall Height	1,055 mm (41.5 in)
Seat Height	760 mm (29.9 in)
Wheelbase	1,385 mm (54.5 in)
Minimum Ground Clearance	145 mm ( 5.7 in)
Basic Weight:	
With Oil and Full Fuel Tank	176 kg (388 lb)
Minimum Turning Radius	2,600 mm (102.4 in)
Engine:	
Engine Type	Air cooled 4-stroke, SOHC
Cylinder Arrangement	Single cylinder
Displacement	595 cm <sup>3</sup>
Bore x Stroke	95.0 x 84.0 mm (3.740 x 3.307 in)
Compression Ratio	8.5 : 1
Compression Pressure	1,177 kPa (12 kg/cm <sup>2</sup> , 171 psi)
Starting System	Kick starter
Lubrication System	Dry sump
Oil Type or Grade: Engine Oil	Yamalube 4-cycle oil or SAE 20W40 type SE motor oil
Oil Capacity:	
Engine Oil:	
Periodic Oil Change	2.0 L (1.8 Imp qt, 2.1 US qt)
With Oil Filter Replacement	2.1 L (1.9 Imp qt, 2.2 US qt)
Total Amount	2.4 L (2.1 Imp qt, 2.5 US qt)
Air Filter	Dry type element
Fuel:	
Type	Regular gasoline
Tank Capacity	15.0 L (3.3 Imp gal, 4.0 US gal)
Reserve Amount	3.0 L (0.7 Imp gal, 0.8 US gal)
Carburetor:	
Type/Manufacturer	Y27PV x 1/TEI KEI KIKAI
Spark Plug:	
Type/Manufacturer	DPR7EA-9, DPR8EA-9, DR7ES/NGK
Gap	For DP type: 0.8 ~ 0.9 mm (0.031 ~ 0.035 in) For D type: 0.6 ~ 0.7 mm (0.024 ~ 0.028 in)
Clutch Type	Wet, multiple-disc

# SPECIFICATIONS



Model	SRX600S																						
<b>Transmission:</b> Primary Reduction System Primary Reduction Ratio Secondary Reduction System Secondary Reduction Ratio Transmission Type Operation Gear Ratio: 1st 2nd 3rd 4th 5th	Gear 74/31 (2.387) Chain 37/15 (2.466) Constant mesh, 5-speed Left foot operation 30/13 (2.307) 27/17 (1.588) 24/20 (1.200) 21/22 (0.954) 21/27 (0.777)																						
<b>Chassis:</b> Frame Type Caster Angle Trail	Double cradle 26" 103 mm (4.06 in)																						
<b>Tire:</b> Type Size (Front)  Size (Rear)  Wear Limit	Tubeless 100/80-18 53s BRIDGESTONE YKD 120/80-18 62S BRIDGESTONE KJK 1.0 mm (0.04 in)																						
<b>Tire Pressure (Cold Tire):</b> Basic Weight: With Oil and Full Fuel Tank Maximum Load*  Cold Tire Pressure: Up to 90 kg (198 lb) Load*  90 kg (198 lb)*~ Maximum Load*  High Speed Riding	<table border="1" style="width: 100%; border-collapse: collapse;"> <tr> <td style="width: 50%; text-align: center;">176 kg (388 lb)</td> <td colspan="2"></td> </tr> <tr> <td style="width: 50%; text-align: center;">204 kg (450 lb)</td> <td colspan="2"></td> </tr> <tr> <td></td> <td style="text-align: center;">FRONT</td> <td style="text-align: center;">REAR</td> </tr> <tr> <td></td> <td style="text-align: center;">177 kPa (1.8 kg/cm<sup>2</sup>, 26 psi)</td> <td style="text-align: center;">196 kPa (2.0 kg/cm<sup>2</sup>, 28 psi)</td> </tr> <tr> <td></td> <td style="text-align: center;">196 kPa (2.0 kg/cm<sup>2</sup>, 28 psi)</td> <td style="text-align: center;">226 kPa (2.3 kg/cm<sup>2</sup>, 32 psi)</td> </tr> <tr> <td></td> <td style="text-align: center;">196 kPa (2.0 kg/cm<sup>2</sup>, 28 psi)</td> <td style="text-align: center;">226 kPa (2.3 kg/cm<sup>2</sup>, 32 psi)</td> </tr> <tr> <td></td> <td colspan="2" style="text-align: center;">* Load is the total weight of cargo, rider, passenger, and accessories.</td> </tr> </table>		176 kg (388 lb)			204 kg (450 lb)				FRONT	REAR		177 kPa (1.8 kg/cm <sup>2</sup> , 26 psi)	196 kPa (2.0 kg/cm <sup>2</sup> , 28 psi)		196 kPa (2.0 kg/cm <sup>2</sup> , 28 psi)	226 kPa (2.3 kg/cm <sup>2</sup> , 32 psi)		196 kPa (2.0 kg/cm <sup>2</sup> , 28 psi)	226 kPa (2.3 kg/cm <sup>2</sup> , 32 psi)		* Load is the total weight of cargo, rider, passenger, and accessories.	
176 kg (388 lb)																							
204 kg (450 lb)																							
	FRONT	REAR																					
	177 kPa (1.8 kg/cm <sup>2</sup> , 26 psi)	196 kPa (2.0 kg/cm <sup>2</sup> , 28 psi)																					
	196 kPa (2.0 kg/cm <sup>2</sup> , 28 psi)	226 kPa (2.3 kg/cm <sup>2</sup> , 32 psi)																					
	196 kPa (2.0 kg/cm <sup>2</sup> , 28 psi)	226 kPa (2.3 kg/cm <sup>2</sup> , 32 psi)																					
	* Load is the total weight of cargo, rider, passenger, and accessories.																						
<b>Brake:</b> Front Brake Type Operation Rear Brake Type Operation	Dual disc brake Right hand operation Single disc brake Right foot operation																						
<b>Suspension:</b> Front Suspension Rear Suspension	Telescopic fork Swingarm																						
<b>Shock Absorber:</b> Front Shock Absorber Rear Shock Absorber	Coil spring, Oil damper Coil spring, Oil/Gas damper																						
<b>Wheel Travel:</b> Front Wheel Travel Rear Wheel Travel	140 mm (5.5 in) 100 mm (3.9 in)																						



# SPECIFICATIONS

Model	SR X600S
<b>Electrical:</b> Ignition System Generator System Battery Type Battery Capacity	CDI AC Magneto generator 12N5-3B 12V, 5AH
<b>Headlight Type</b>	<b>Bulb type (Quartz bulb)</b>
<b>Bulb Wattage/Quantity:</b> Headlight Tail/Brake Light Flasher Light Indicator Light: "NEUTRAL" "HIGH BEAM" "TURN" Meter Light	12V, 60W/55W x 1 12V, 8W/27W x 1 12V, 27W x 4 12V, 3.4W x 1 12V, 3.4W x 1 12V, 3.4W x 1 12V, 3.4W x 2



MAINTENANCE SPECIFICATIONS

Engine

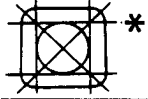
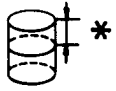
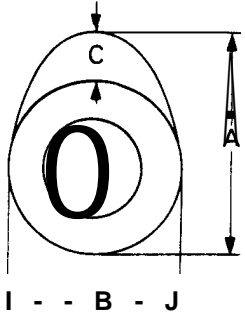
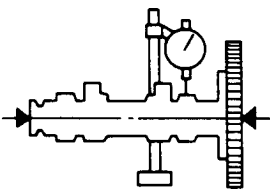
Model	SRX600S
Cylinder Head: Warp Limit 	$< 0.03 \text{ mm (0.0012 in)} >$ ‡Lines indicate straightedge measurement.
Cylinder: Bore Size Measuring Point* Out of Round Limit 	95.00 - 95.02 mm (3.740 - 3.741 in) 40 mm (1.57 in) 0.05 mm (0.002 in)
Camshaft: Drive Method Cam Cap Inside Diameter Camshaft Outside Diameter Shaft-to-cap Clearance Cam Dimensions: Intake: "A" $< \text{Limit} >$ "B" $< \text{Limit} >$ "C" Exhaust: "A" $< \text{Limit} >$ "B" $< \text{Limit} >$ "C" Camshaft Runout Limit  	Chain (Left) 23.000 - 23.021 mm (0.9055 - 0.9063 in) 22.967 - 22.980 mm (0.9042 - 0.9047 in) 0.020 - 0.054 mm (0.0008 - 0.0021 in)  36.47 - 36.57 mm (1.436 ~ 1.440 in) $< 36.42 \text{ mm (1.434 in)} >$ 30.06 - 30.16 mm (1.183 - 1.187 in) $< 30.01 \text{ mm (1.182 in)} >$ 6.41 mm (0.252 in)  36.62 - 36.72 mm (1.442 - 1.446 in) $< 36.57 \text{ mm (1.440 in)} >$ 30.11 - 30.21 mm (1.185 - 1.189 in) $< 30.06 \text{ mm (1.184 in)} >$ 6.51 mm (0.256 in) $< 0.03 \text{ mm (0.001 in)} >$  Cam Chain Type/Number of Links Cam Chain Adjustment Method
Rocker Arm/Rocker Arm Shaft: Arm Inside Diameter $< \text{Limit} >$ Shaft Outside Diameter $< \text{Limit} >$ Arm-to-shaft Clearance	75-010/126 Links Automatic  12.000 - 12.018 mm (0.4724 - 0.4731 in) $< 12.05 \text{ mm (0.474 in)} >$ 11.976 - 11.991 mm (0.4715 - 0.4721 in) $< 11.95 \text{ mm (0.471 in)} >$ 0.009 - 0.042 mm (0.0004 - 0.0017 in)







Model	SRX600S		
Valve, Valve Seat, Valve Guide: Valve Clearance (Cold):	IN. EX	0.05 - 0.10 mm (0.002 ~ 0.004 in) 0.12 - 0.17 mm (0.005 - 0.007 in)	
Valve Dimensions:			
<p>Head Dia.</p>	<p>Face Width</p>	<p>Seat Width</p>	<p>Margin Thickness</p>
"A" Head Diameter:	IN. EX.	35.9 - 36.1 mm (1.413 - 1.421 in) 30.9 - 31.1 mm (1.217 - 1.224 in)	
"B" Face Width:	IN. EX.	2.26 mm (0.089 in) 2.26 mm (0.089 in)	
"C" Seat Width:	IN. EX.	1.0 - 1.2 mm (0.039 ~ 0.047 in) 1.0 - 1.2 mm (0.039 ~ 0.047 in)	
< Limit >	IN. EX.	< 2.0 mm (0.080 in) > < 2.0 mm (0.080 in) >	
"D" Margin Thickness:	IN. EX.	1.0 - 1.4 mm (0.039 - 0.055 in) 0.8 - 1.2 mm (0.031 - 0.047 in)	
< Limit >	IN. EX.	< 0.7 mm (0.028 in) > < 0.7 mm (0.028 in) >	
Stem Outside Diameter:	IN. EX.	6.975 - 6.990 mm (0.2746 - 0.2752 in) 6.955 - 6.970 mm (0.2738 - 0.2744 in)	
< Limit >	IN. EX.	< 6.945 mm (0.273 in) > < 6.915 mm (0.272 in) >	
Guide Inside Diameter:	IN. EX.	7.000 - 7.012 mm (0.2756 - 0.2761 in) 7.000 - 7.012 mm (0.2756 - 0.2761 in)	
< Limit >	IN. EX.	< 7.10 mm (0.280 in) > < 7.10 mm (0.280 in) >	
Stem-to-guide Clearance:	IN. EX.	0.010 - 0.037 mm (0.0004 - 0.0015 in) 0.030 ~ 0.057 mm (0.0012 - 0.0022 in)	
< Limit >	IN. EX.	< 0.10 mm (0.004 in) > < 0.12 mm (0.005 in) >	
Stem Runout Limit		< 0.01 mm (0.0004 in) >	

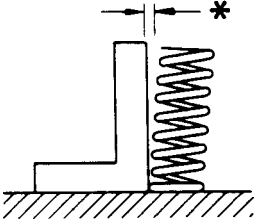
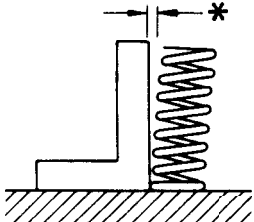
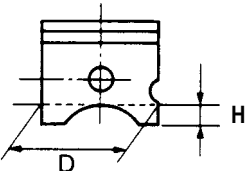

Model	SRX600S	
<p>Valve Spring:                      Inner Spring:                      Free Length                      IN.                          EX.                      &lt; Limit &gt;                            IN.                          EX.                      Set Length (Valve Closed)    IN.                          EX.                      Compressed Pressure (Installed) IN.                          EX.                      Tilt Limit *                            IN.                          EX.</p>  <p>Direction of Winding                IN.                          EX.</p> <p>Outer Spring:                      Free Length                            IN.                          EX.                      &lt; Limit &gt;                                IN.                          EX.                      Set Length (Valve Closed)        IN.                          EX.                      Compressed Pressure (Installed) IN.                          EX.                      Tilt Limit *                                IN.                          EX.</p>  <p>Direction of Winding                IN.                          EX.</p>	<p>40.1 mm (1.58 in)                      40.1 mm (1.58 in)                      &lt; 38.1 mm (1.50 in) &gt;                      &lt; 38.1 mm (1.50 in) &gt;                      22.7 mm (0.89 in)                      22.7 mm (0.89 in)                      16.8 - 19.4 kg (37.0 - 42.8 lb)                      16.8 - 19.4 kg (37.0 - 42.8 lb)                      &lt; 2.5°/1.7 mm (0.067 in) &gt;                      &lt; 2.5°/1.7 mm (0.067 in) &gt;</p> <p>Right                      Right</p> <p>43.8 mm (1.72 in)                      43.8 mm (1.72 in)                      &lt; 41.8 mm (1.65 in) &gt;                      &lt; 41.8 mm (1.65 in) &gt;                      34.2 mm (1.35 in)                      34.2 mm (1.35 in)                      37.1 - 49.6 kg (81.8 - 109.3 lb)                      37.1 - 49.6 kg (81.8 - 109.3 lb)                      &lt; 2.5°/1.7 mm (0.067 in) &gt;                      &lt; 2.5°/1.7 mm (0.067 in) &gt;</p> <p>Left                      Left</p>	
<p>Piston :                      Piston Size "D"/                      Measuring Point "H"</p>  <p>Piston Clearance                      Oversize:    2nd                                        4th</p>	<p>94.915 - 94.965 mm (3.737 - 3.739 in)/                      5 mm (0.20 in)                      (From bottom line of piston skirt)                      0.045 - 0.065 mm (0.0018 - 0.0026 in)                      95.50 mm (3.760 in)                      96.00 mm (3.780 in)</p>	



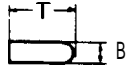

Model	SRX600S
<p><b>Piston Ring:</b> Sectional Sketch:</p> <p>Top Ring </p> <p>2nd Ring </p> <p>Oil Ring </p> <p>End Gap (Installed):</p> <p>Top Ring 0.30 ~ 0.45 mm (0.012 ~ 0.018 in)</p> <p>2nd Ring 0.30 ~ 0.45 mm (0.012 ~ 0.018 in)</p> <p>Oil Ring 0.2 ~ 0.7 mm (0.008 ~ 0.028 in)</p> <p>&lt; Limit &gt;</p> <p>Top Ring &lt; 0.60 mm (0.024 in) &gt;</p> <p>2nd Ring &lt; 0.60 mm (0.024 in) &gt;</p> <p>Side Clearance (Installed):</p> <p>Top Ring 0.04 ~ 0.08 mm (0.0016 ~ 0.0031 in)</p> <p>2nd Ring 0.03 ~ 0.07 mm (0.0012 ~ 0.0028 in)</p> <p>&lt; Limit &gt;</p> <p>Top Ring &lt; 0.10 mm (0.0039 in) &gt;</p> <p>2nd Ring &lt; 0.11 mm (0.0043 in) &gt;</p>	<p>Barrel</p> <p>B = 1.2 mm (0.05 in)</p> <p>T = 3.8 mm (0.15 in)</p> <p>Taper</p> <p>B = 1.2 mm (0.05 in)</p> <p>T = 3.8 mm (0.15 in)</p> <p>Expander</p> <p>B = 2.5 mm (0.10 in)</p> <p>T = 3.4 mm (0.13 in)</p>
<p>Crankshaft: F</p> <p>Crank Width "A"</p> <p>&lt; Runout Limit "B" &gt;</p> <p>Small End Free Play "F"</p> <p>&lt; Limit &gt;</p> <p>Big End Radial Clearance "C"</p>	<p>74.95 ~ 75.00 mm (2.951 ~ 2.953 in)</p> <p>&lt; 0.03 mm (0.001 in) &gt;</p> <p>0.8 mm (0.031 in)</p> <p>&lt; 2.0 mm (0.08 in) &gt;</p> <p>0.25 ~ 0.75 mm (0.010 ~ 0.030 in)</p>
<p>Balancer Drive Method</p>	<p>Gear</p>
<p>Clutch:</p> <p>Friction Plate Thickness/Quantity</p> <p>Wear Limit</p> <p>Clutch Plate Thickness/Quantity</p> <p>Warp Limit</p> <p>Clutch Spring Free Length/Quantity</p> <p>Clutch Spring Minimum Length</p> <p>Push Rod Bending Limit</p>	<p>Type A: 2.90 ~ 3.10 mm (0.114 ~</p>

**SPECIFICATIONS**



Model	SRX600S																																			
<b>Transmission:</b> Main Axle Deflection Limit Drive Axle Deflection Limit	< 0.08 mm (0.0031 in) > < 0.08 mm (0.0031 in) >																																			
<b>Kick Starter:</b> Kick Starter Type	Ratchet Type																																			
<b>Decompression Device:</b> Type Cable Free Play	Kick synchronous 3 - 5 mm (0.12 - 0.20 in)																																			
<b>Air Filter Oil Grade (Oiled Filter)</b>	SAE 10W30 SE motor oil																																			
<b>Carburetor:</b> I.D. Mark  Main Jet (M.J.) Main Air Jet (M.A.J.) Jet Needle-Clip Position (J.N.) Main Nozzle (M.N.)  Cutaway (C.A.) Pilot Jet (P.J.) Pilot Air Jet (P.A.J.) Enricher Air Jet (E.A.J.) Pilot Screw (P.S.) Valve Seat (V.S.) Starter Jet (G.S.) Fuel Level (F.L.) Float Level Engine Idling Speed Vacuum Pressure at Idling Speed	<table border="1"> <thead> <tr> <th colspan="2" data-bbox="792 580 1101 623">2EF00</th> </tr> <tr> <th data-bbox="792 623 1101 666">Primary carburetor</th> <th data-bbox="1101 623 1421 666">Secondary carburetor</th> </tr> </thead> <tbody> <tr> <td data-bbox="792 666 1101 708">#118</td> <td data-bbox="1101 666 1421 708">#100</td> </tr> <tr> <td data-bbox="792 708 1101 751">φ0.8</td> <td data-bbox="1101 708 1421 751">\$1.3</td> </tr> <tr> <td data-bbox="792 751 1101 793">5C3F-1/1</td> <td data-bbox="1101 751 1421 793">5Z71-1/1</td> </tr> <tr> <td data-bbox="792 793 1101 836">φ2.60</td> <td data-bbox="1101 793 1421 836">φ2.60</td> </tr> <tr> <td colspan="2" data-bbox="792 836 1421 878">#5.5</td> </tr> <tr> <td colspan="2" data-bbox="792 878 1421 921">#46</td> </tr> <tr> <td colspan="2" data-bbox="792 921 1421 963">φ0.6</td> </tr> <tr> <td colspan="2" data-bbox="792 963 1421 1006">φ1.1</td> </tr> <tr> <td colspan="2" data-bbox="792 1006 1421 1049">2.0 ± 1/2</td> </tr> <tr> <td colspan="2" data-bbox="792 1049 1421 1091">\$2.5</td> </tr> <tr> <td colspan="2" data-bbox="792 1091 1421 1134">φ0.64</td> </tr> <tr> <td colspan="2" data-bbox="792 1134 1421 1176">6.5 - 7.5 mm (0.26 - 0.30 in)</td> </tr> <tr> <td colspan="2" data-bbox="792 1176 1421 1219">26 - 28 mm (1.02 - 1.10 in)</td> </tr> <tr> <td colspan="2" data-bbox="792 1219 1421 1261">1,250 - 1,350 r/min</td> </tr> <tr> <td colspan="2" data-bbox="792 1261 1421 1304">26.6 kPa (200 mmHg, 7.9 inHg) or more</td> </tr> </tbody> </table>		2EF00		Primary carburetor	Secondary carburetor	#118	#100	φ0.8	\$1.3	5C3F-1/1	5Z71-1/1	φ2.60	φ2.60	#5.5		#46		φ0.6		φ1.1		2.0 ± 1/2		\$2.5		φ0.64		6.5 - 7.5 mm (0.26 - 0.30 in)		26 - 28 mm (1.02 - 1.10 in)		1,250 - 1,350 r/min		26.6 kPa (200 mmHg, 7.9 inHg) or more	
2EF00																																				
Primary carburetor	Secondary carburetor																																			
#118	#100																																			
φ0.8	\$1.3																																			
5C3F-1/1	5Z71-1/1																																			
φ2.60	φ2.60																																			
#5.5																																				
#46																																				
φ0.6																																				
φ1.1																																				
2.0 ± 1/2																																				
\$2.5																																				
φ0.64																																				
6.5 - 7.5 mm (0.26 - 0.30 in)																																				
26 - 28 mm (1.02 - 1.10 in)																																				
1,250 - 1,350 r/min																																				
26.6 kPa (200 mmHg, 7.9 inHg) or more																																				
<b>Lubrication System:</b> Oil Filter Type Oil Pump Type Tip Clearance < Limit > Side Clearance < Limit > Bypass Valve Setting Pressure  Relief Valve Operating Pressure	Paper, Wire mesh Trochoid pump 0.12 mm (0.005 in) < 0.17 mm (0.007 in) > 0.03 - 0.08 mm (0.001 - 0.003 in) < 0.08 mm (0.003 in) > 78.5 - 117.7 kPa (0.8 - 1.2 kg/cm <sup>2</sup> , 11.4 - 17.1 psi) 78.5 - 117.7 kPa (0.8 - 1.2 kg/cm <sup>2</sup> , 11.4 - 17.1 psi)																																			

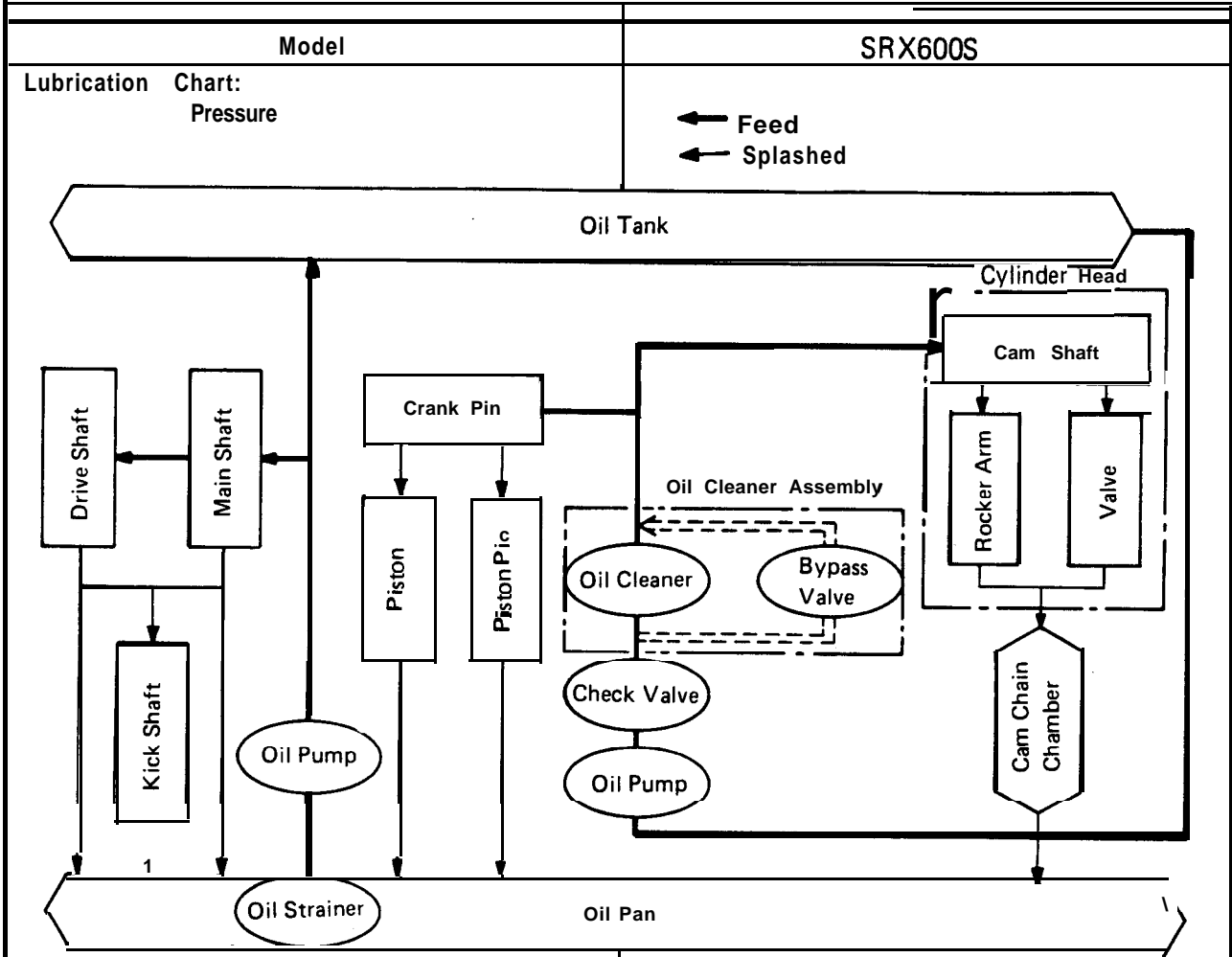

**Crankcase Tightening Sequence:**  
Left Side

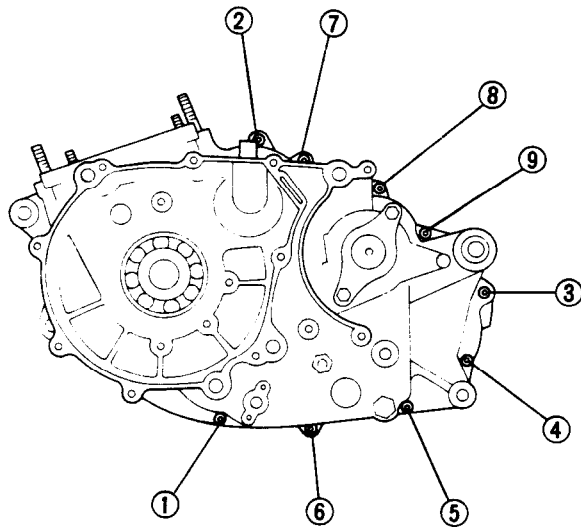

**Right Side**

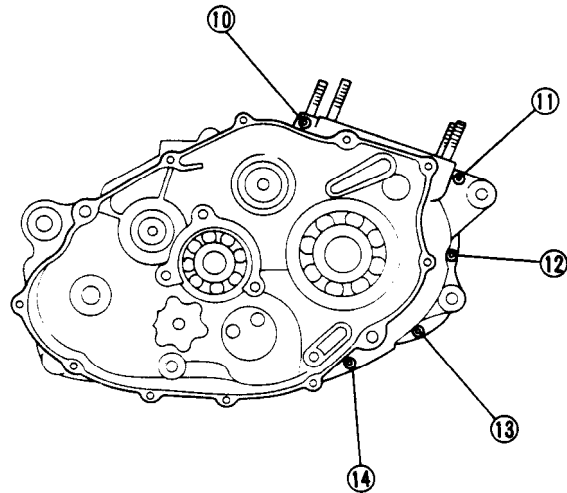

**SPECIFICATIONS**



Tightening Torque							Remarks
Parts to be tightened	Part name	Thread size	Q'ty	Tightening torque			
				Nm	m-kg	ft·lb	
<b>ENGINE:</b>							
Cylinder Head	Flange bolt	M8 x 1.25	4	25	2.5	18	Use lock washer
	Nut	M10 x 1.25	2	20	2.0	14	
	Bolt	M6	1	10	1.0	7.2	
	Stud bolt	M6	4	7	0.7	5.1	
Spark Plug	—	M12 x 1.25	1	17.5	1.75	12.5	
Cylinder Head Cover	Bolt	M6	16	10	1.0	7.2	
Tappet Cover	Bolt	M6	2	10	1.0	7.2	
	Bolt	M32 x 1.5	2	12	1.2	8.7	
Cylinder	Cap nut	M8 x 1.25	2	22	2.2	16	
	Nut	M10 x 1.25	4	38	3.8	27	
	Bolt	M 6 x 1.25	2	10	1.0	7.2	
Balance Weight Gear	Nut	M16 x 1.0	1	90	9.0	65	
A.C. Generator Rotor	N u t	M14 x 1.5	1	90	9.0	65	
Valve Clearance	Nut	M6	4	14	1.4	10	
Stopper Guide	Bolt	M6	2	8	0.8	5.8	
Cam Sprocket	Flange bolt	M7	2	20	2.0	14	
Tensioner Assembly	Bolt	M6	2	10	1.0	7.2	
Decompression Cam	Bolt	M6	1	8	0.8	5.8	
Rocker Shaft Stopper	Bolt	M6	2	10	1.0	7.2	
Oil Pump Assembly	Bolt	M6	3	10	1.0	7.2	
Oil Pump Cover	Screw	M6	1	7	0.7	5.1	
Strainer Housing	Screw	M6	2	7	0.7	5.1	
Drain Plug	Plug	M14 x 1.5	1	30	3.0	22	
Oil Filter Cover	Bolt	M6	3	10	1.0	7.2	
Oil Filter Air Bleed	Screw	M5	1	5	0.5	3.6	
Oil Hose	Bolt	M6	4	10	1.0	7.2	
	Union nut	M16 x 1.5	2	50	5.0	36	
Carburetor Joint	Bolt	M6	4	10	1.0	7.2	
Carburetor Assembly	Hose clamp	M4	2	2	0.2	1.4	
Exhaust Pipe	Nut	M6	4	10	1.0	7.2	
Exhaust Pipe Protector	Screw	M6	2	7	0.7	5.1	
Outlet Pipe	Screw	M6	1	7	0.7	5.1	
Exhaust Pipe Muffler Joint	Bolt	M8 x 1.25	1	20	2.0	14	
Muffler Mounting	Bolt	M8 x 1.25	2	27	2.7	19	
Crankcase	Bolt	M6	14	10	1.0	7.2	
Crankcase	Stud bolt	M10 x 1.25	4	20	2.0	14	
Clamp (Lead)	Screw	M6	1	7	0.7	5.1	
Decompression Cover	Bolt	M6	2	10	1.0	7.2	
Bridge Plate Cover	Screw	M6	3	7	0.7	5.1	
Ratchet Wheel Guide	Bolt	M6	2	10	1.0	7.2	
Decompression Lever	Nut	M6	1	8	0.8	5.8	



Parts to be tightened	Part name	Thread size	Q'ty	Tightening torque			Remarks
				N m	m·kg	ft·lb	
Clutch Boss	Nut	M20 x 1.0	1	70	7.0	50	Use lock washer Use lock washer
Primary Drive Gear	Nut	M20 x 1.0	1	110	11.0	80	
Push Lever Stopper	Screw	M 8 x 1.0	1	12	1.2	8.7	
Push Lever Positioning	Nut	M6	1	8	0.8	5.8	
Drive Sprocket	Bolt	M6	2	10	1.0	7.2	
Oil Seal Cover	Bolt	M6	2	10	1.0	7.2	
Stopper Lever	Nut	M6	1	10	1.0	7.2	
Shift Pedal	Bolt	M6	1	10	1.0	7.2	
Coil	Screw	M6	6	7	0.7	5.1	
Tensioner End Plug	Plug	M32 x 1.5	1	20	2.0	14	
Kick crank	Nut	M14	1	50	5.0	36	





Model	SRX600S
<b>Front Disc Brake:</b> Type Outside Diameter x Thickness < Limit > Pad Thickness < Limit > Master Cylinder Inside Diameter Caliper Cylinder Inside Diameter Brake Fluid Type	Dual disc 267 x 5 mm (10.5 x 0.20 in) < 4.5 mm (0.18 in) > 5.5 mm (0.22 in) < 0.5 mm (0.02 in) > 15.8 mm (0.62 in) 38.18 mm (1.50 in) DOT #3
<b>Rear Disc Brake:</b> Type Outside Diameter x Thickness < Limit > Pad Thickness < Limit > Master Cylinder Inside Diameter Caliper Cylinder Inside Diameter Brake Fluid Type	Single disc 245 x 5 mm (9.6 x 0.20 in) < 4.5 mm (0.18 in) > 5.5 mm (0.22 in) < 0.5 mm (0.02 in) > 14 mm (0.55 in) 38.18 mm (1.50 in) DOT #3
<b>Brake Lever &amp; Brake Pedal:</b> Brake Lever Free Play Brake Pedal Position	2 ~ 5 mm (0.08 ~ 0.20 in) 50 mm (2.0 in) Below the top of the footrest
Clutch Lever Free Play/Position	2 ~ 3 mm (0.08 ~ 0.12 in)/at lever pivot



## Tiahtenino Torau

Parts to be tightened	Thread size	Tightening torque			Remarks
		Nm	m - kg	ft·lb	
<b>CHASSIS:</b>					
Front Wheel Axle	M14 x 1.5	105	10.5	75	See NOTE
Rear Wheel Axle	M16 x 1.5	105	10.5	75	
Front Fork and Fork Brace	M6 x 1.0	9	0.9	6.5	
Steering Crown and Inner Tube	M8 x 1.25	20	2.0	14	
Steering Crown and Steering Shaft	M22 x 1.0	110	11.0	80	
Handlebar and Inner Tube	M8 x 1.25	20	2.0	14	
Handlebar and Steering Crown	M6 x 1.0	9	0.9	6.5	
Steering Shaft and Ring Nut	M25 x 1.0	38	3.8	27	
Front Master Cylinder and Master Bracket	M6 x 1.0	9	0.9	6.5	
Front Master Cylinder and Master Cylinder Cap	M5 x 0.8	1	0.1	0.7	
Brake Hose and Union Bolt	M10 x 1.25	25	2.5	18	
Brake Joint and Under Bracket	M6 x 1.0	9	0.9	6.5	
Caliper and Bleed Screw	M8 x 1.25	5	0.5	3.6	
Front Caliper and Front Fork	M10 x 1.25	35	3.5	25	
Engine Stay and Frame	M8 x 1.25	33	3.3	24	
Engine Mounting (Front Upper)	M10 x 1.25	42	4.2	30	
Engine Mounting (Front Lower)	M10 x 1.25	42	4.2	30	
Engine Mounting (Rear Upper)	M10 x 1.25	42	4.2	30	
Engine Mounting (Rear Under)	M10 x 1.25	42	4.2	30	
Engine Stay and Frame (Top)	M8 x 1.25	33	3.3	24	
Engine Mounting (Top)	M10 x 1.25	42	4.2	30	
Frame and Down Tube	M8 x 1.25	25	2.5	18	
Pivot Shaft	M14 x 1.5	90	9.0	65	
Rear Shock Absorber (Top)	M8 x 1.25	26	2.6	19	
Rear Shock Absorber (Bottom)	M10 x 1.25	41	4.1	30	
Rear Master Cylinder and Frame	M8 x 1.25	20	2.0	14	
Footrest Bracket and Frame	M8 x 1.25	26	2.6	19	
Brake Disc and Cast Wheel	M8 x 1.25	20	2.0	14	
Rear Caliper and Caliper Bracket	M10 x 1.25	35	3.5	25	
Rear Sprocket Wheel	M8 x 1.25	32	3.2	23	
Tension Bar	M8 x 1.25	25	2.5	18	
Kick Crank Stopper and Frame	M8 x 1.25	25	2.5	18	
Swingarm End and Swingarm	M6 x 1.0	6	0.6	4.3	
Inner Tube and Under Bracket	M12 x 1.25	38	3.8	27	
Cross Tube and Down Tube	M10 x 1.25	35	3.5	25	
Rear Footrest Bracket and Frame	M10 x 1.25	64	6.4	46	
Rear Footrest Bracket and Frame	M10 x 1.25	30	3.0	22	

## NOTE:

1. First, tighten the ring nut approximately 38 Nm (3.8 m·kg, 27 ft·lb) by using the torque wrench, then loosen the ring nut one turn.
2. Retighten the ring nut 10 Nm (1.0 m·kg, 7.2 ft·lb).

Electrical

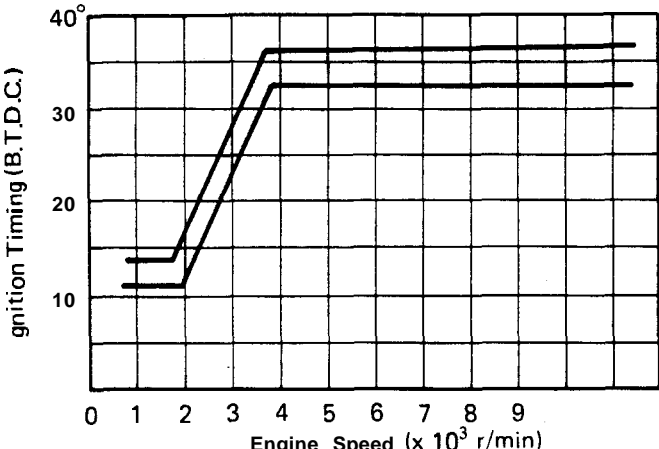
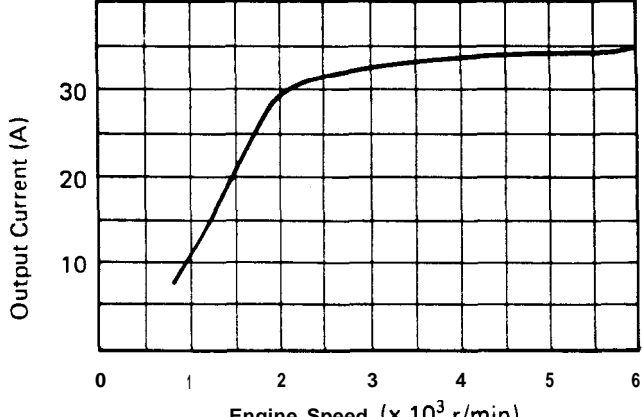
Model	SRX600S
Voltage	12v
Ignition System: Ignition Timing (B.T.D.C.) Advancer Type	12" at 1,200 r/min Electrical
	
CDI: Magneto-Model/Manufacturer Pickup Coil Resistance (Color)  Source Coil Resistance (Color)  CDI Unit-Model/Manufacturer	VCD48/NIPPONDENSO 92 ~ 138Ω at 20°C (68°F) (Green -White/Green) (Green - White/Red) 84 ~ 156Ω at 20°C (68" F) (Brown - Red) QAB50/NIPPONDENSO
Ignition Coil: Model/Manufacturer Minimum Spark Gap Primary Winding Resistance Secondary Winding Resistance Spark Plug Cap Resistance	12970-102/NIPPONDENSO 6 mm (0.24 in) 0.48 ~ 0.72Ω at 20°C (68°F) 5.2 ~ 7.8 kΩ at 20°C (68" F) 5 kΩ
Charging System	AC Magneto generator
AC Generator: Model/Manufacturer Nominal Output	VCD48/NIPPON DENSO 14.5V, 11A at 5,000 r/min
	

**7**

SPECIFICATIONS **APPX** 

Model	SRX600S
Charging Coil Resistance (Color)	0.2 ~ 0.6Ω at 20°C (68°F) (Yellow-White/Yellow)
Voltage Regulator: Type Model/Manufacturer No Load Regulated Voltage	Short control SH565/SHINDENGEN 14 ~ 15v
Rectifier: Model/Manufacturer Capacity Withstand Voltage	SH565/SHINDENGEN 12A 200v
Battery : Capacity Specific Gravity	12V, 5AH 1.280
Horn : Type/Quantity Model/Manufacturer Maximum Amperage	Plain type/1 MF-12/NIKKO 1.5A
Flash Relay: Type Model/Manufacturer Self Cancelling Device Flasher Frequency Wattage	Condenser type FU257CD/NIPPONDENSO Yes 75 ~ 95 cycle/min 27W x 2 + 3.4W
Circuit Breaker: Type	Non fuse breaker



**GENERAL TORQUE SPECIFICATIONS**

This chart specifies torque for standard fasteners with standard I.S.O. pitch threads. Torque specifications for special components or assemblies are included in the applicable sections of this book. To avoid warpage, tighten multi-fastener assemblies in a crisscross fashion, in progressive stages, until full torque is reached. Unless otherwise specified, torque specifications call for clean, dry threads. Components should be at room temperature.

A (Nut)	B (Bolt)	General torque specifications		
		Nm	m•kg	ft•lb
10 mm	6 mm	6	0.6	4.3
12 mm	8 mm	15	1.5	11
14 mm	10 mm	30	3.0	22
17 mm	12 mm	55	5.5	40
19 mm	14 mm	85	8.5	61
22 mm	16 mm	130	13.0	94

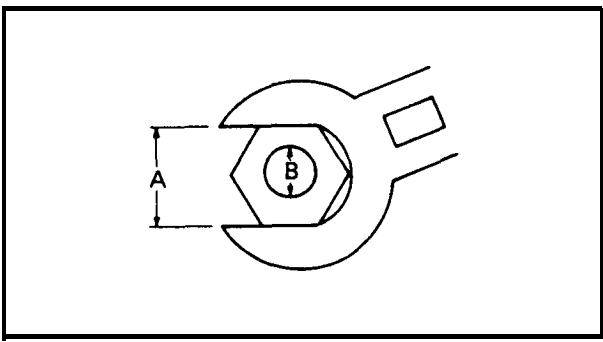

A: Distance across flats  
B: Outside thread diameter

**DEFINITION OF UNITS**

Unit	Read	Definition	Measure
m m	millimeter	10 <sup>-3</sup> meter	Length
cm	centimeter	10 <sup>-2</sup> meter	Length
kg	kilogram	10 <sup>3</sup> gram	Weight
N	Newton	1 kg x m/sec <sup>2</sup>	Force
Nm	Newton meter	N x m	Torque
m•kg	Meter kilogram	m x kg	Torque
Pa	Pascal	N/m <sup>2</sup>	Pressure
N/mm	Newton per millimeter	N/mm	Spring rate
L	Liter	—	Volume or Capacity
cm <sup>3</sup>	Cubic centimeter	—	Volume or Capacity
r/min	Rotation per minute	—	Engine Speed

**7**

LUBRICATION DIAGRAM

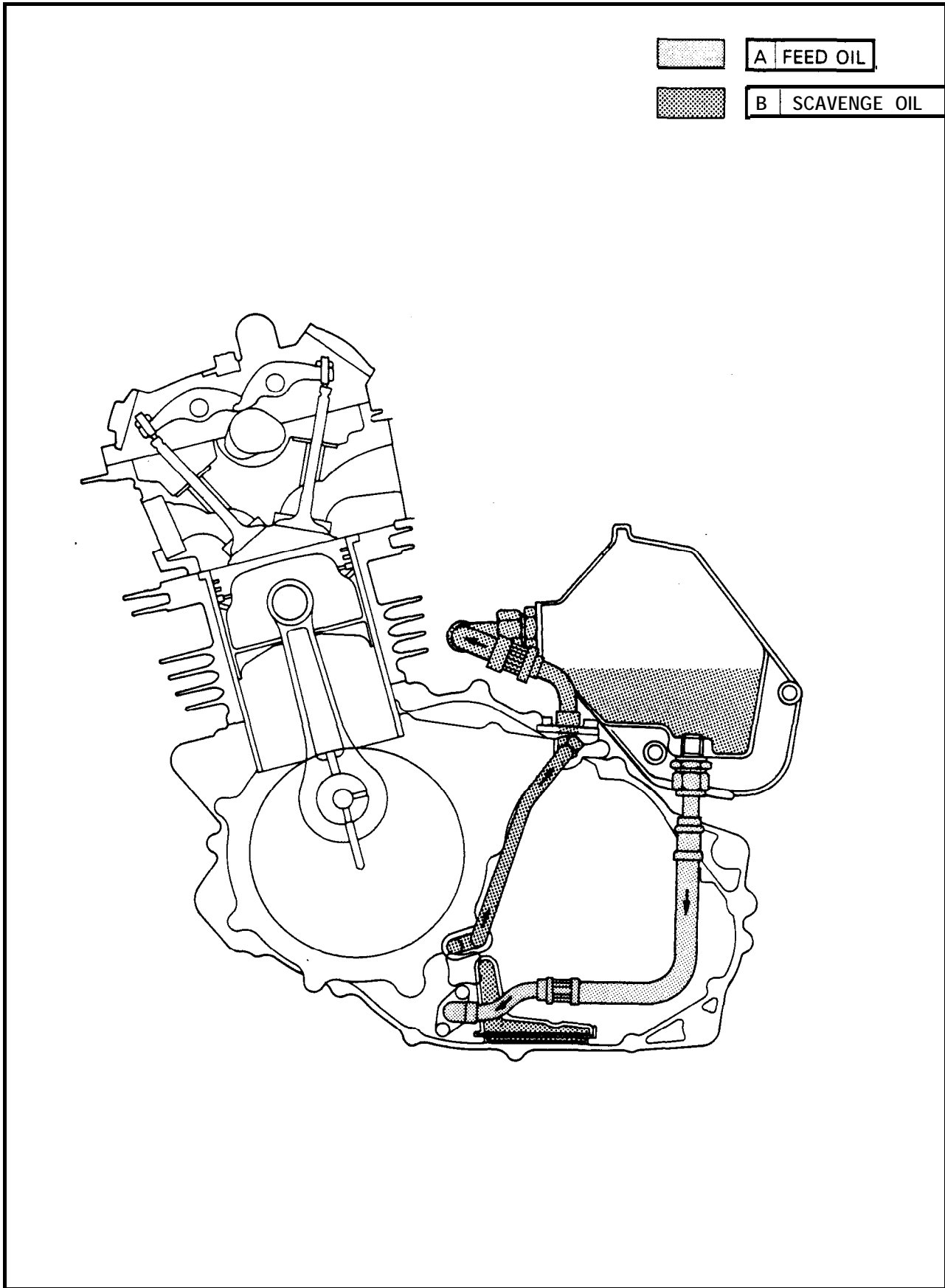



A FEED OIL

B SCAVENGE OIL

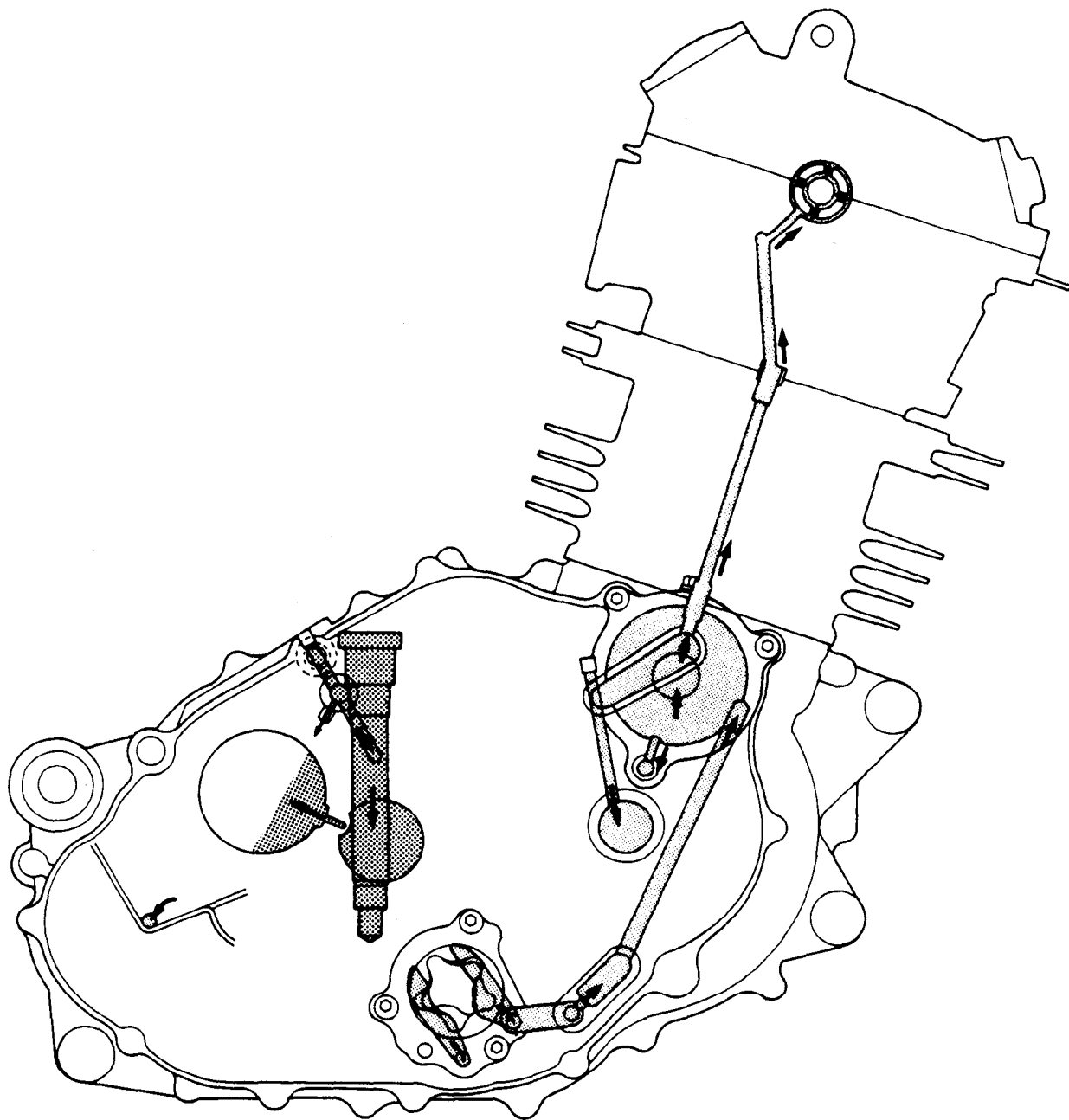

LUBRICATION DIAGRAM

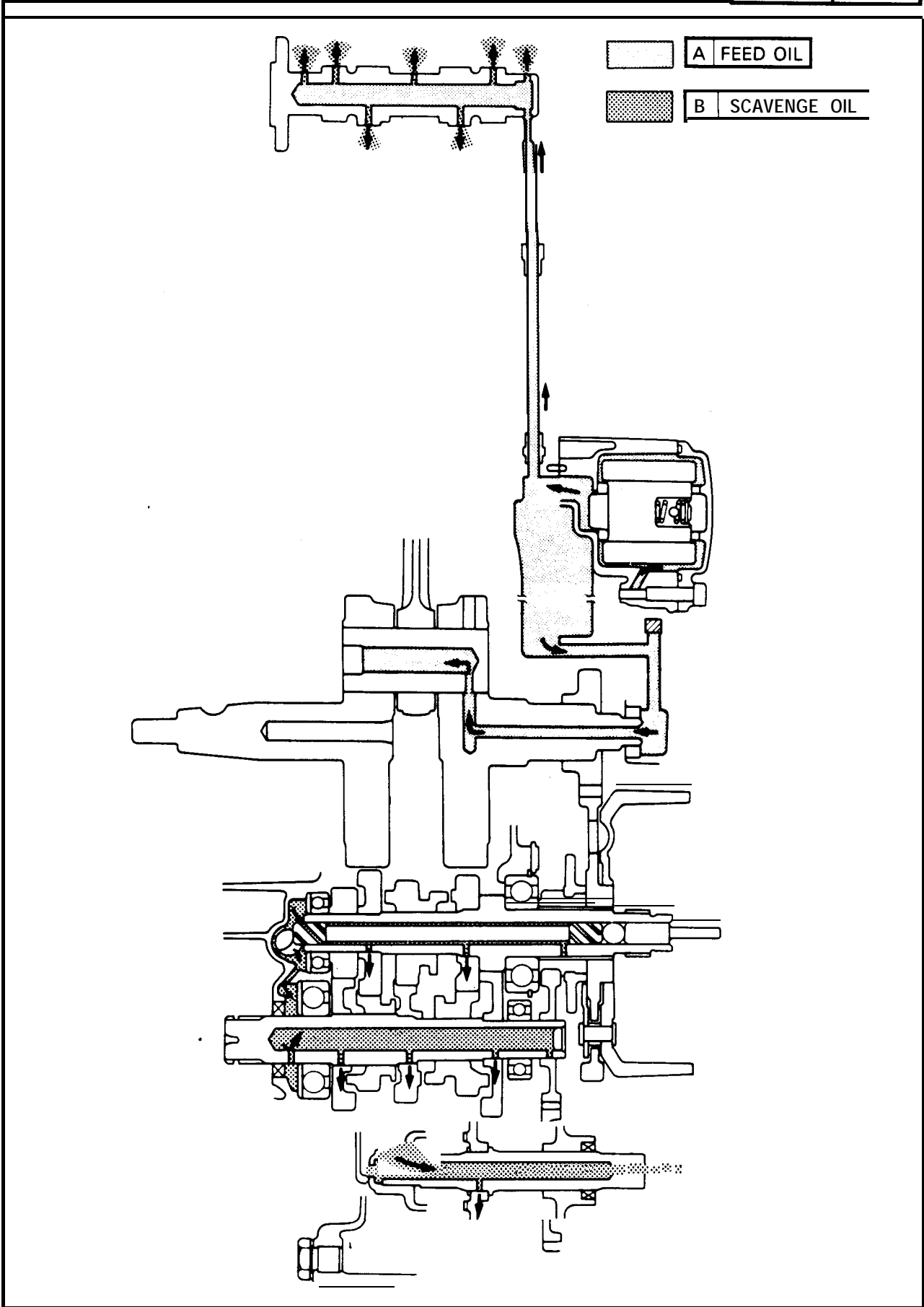



A FEED OIL



B SCAVENGE OIL

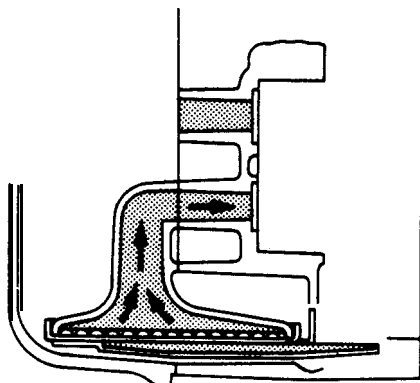
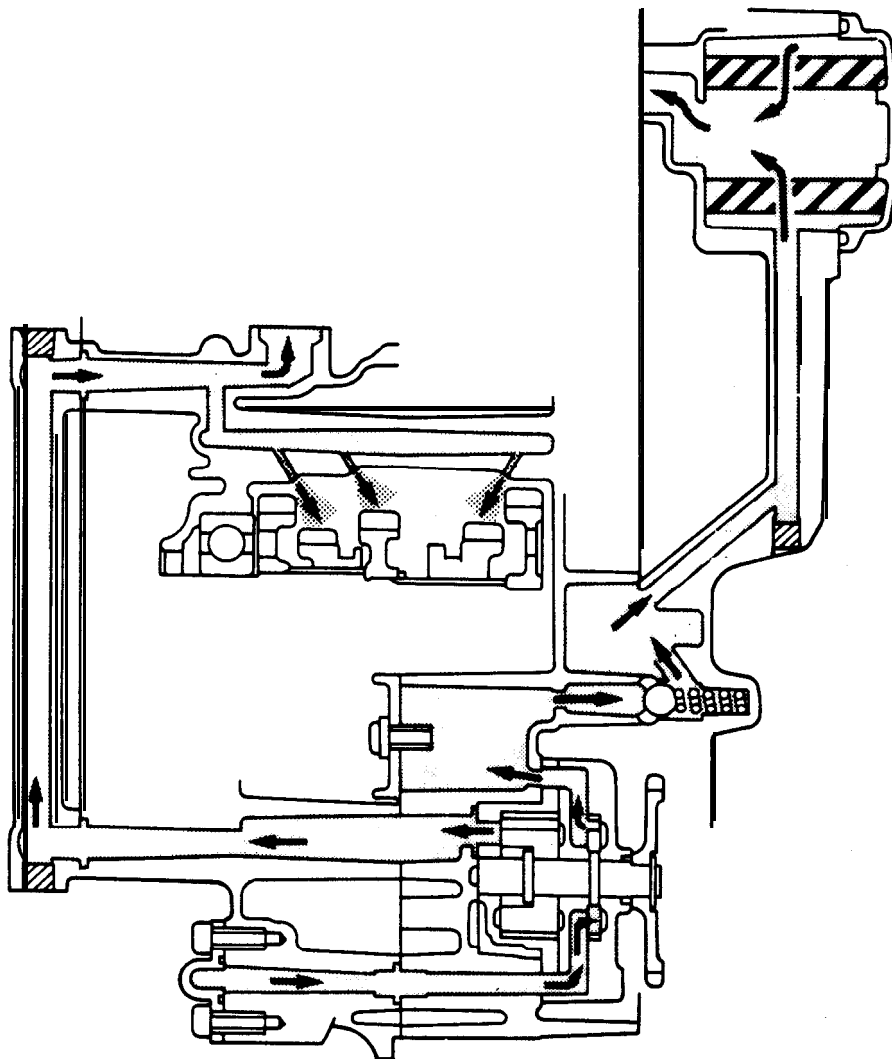

## CABLE ROUTING

- ① Meter light lead
- ② Clutch cable
- ③ Handlebar switch (Left) lead
- ④ Starter cable
- ⑤ Main switch lead
- ⑥ Wire harness
- @Speedometer cable
- ⑧ Front flasher light leads (Left and right)
- ⑨ Tachometer cable
- ⑩ Throttle cables
- ⑪ Handlebar switch (Right) lead
- ⑫ Front brake switch lead
- ⑬ Brake hose

- Connect the lead into the headlight body.
- Pass the handlebar switch (Left) lead behind the clutch cable, and connect the lead into the headlight body.
- Cross the wire harness in front of the steering head pipe.
- Pass the handlebar switch (Right) lead behind the brake hose, and connect the lead into the headlight body.

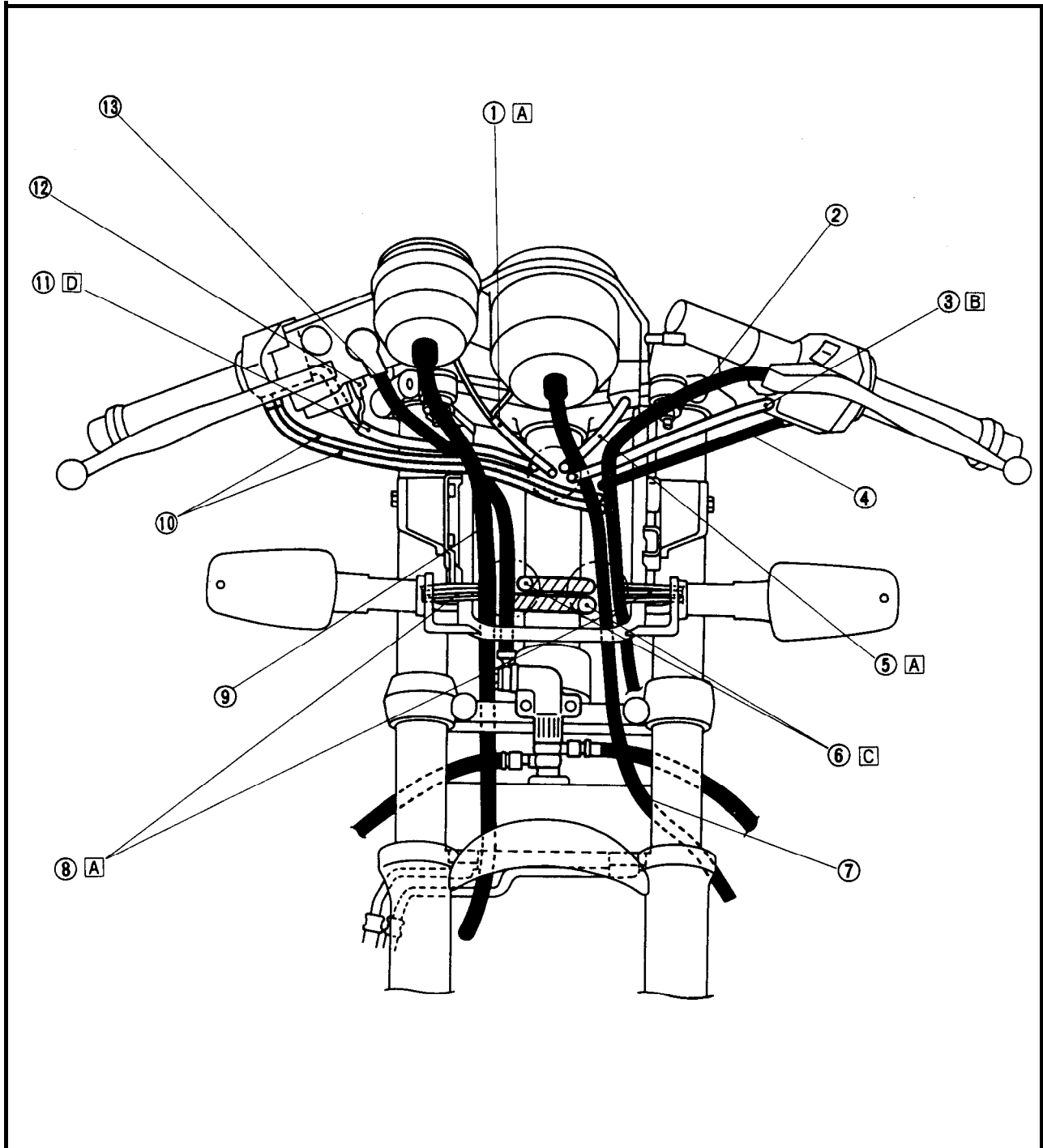

**CABLE ROUTING**

- |                           |                          |  |
|---------------------------|--------------------------|--|
| ① Throttle cables         | ⑨ Battery breather hose  | ⑰ Ignition coil lead   |
| ② Clamp                   | ⑩ Rear brake switch lead | ⑱ Ignition coil  |
| ③ Brake hose              | ⑪ Reservoir tank hose    | ⑲ Ground lead  |
| ④ Tachometer cable        | ⑫ Taillight lead         | ⑳ Flasher relay  |
| ⑤ High tension cord       | ⑬ Battery                | <input type="checkbox"/> Pass the hoses into the guides.                                       |
| ⑥ Overflow hose           | ⑭ Wire harness           | <input type="checkbox"/> Pass the hoses outside of the reservoir tank hose.                    |
| ⑦ Rear brake switch       | ⑮ Ventilation hose       | <input type="checkbox"/> Pass the breather hose between the primary and secondary carburetors. |
| ⑧ Fuel tank breather hose | ⑯ Oil tank breather hose |  |

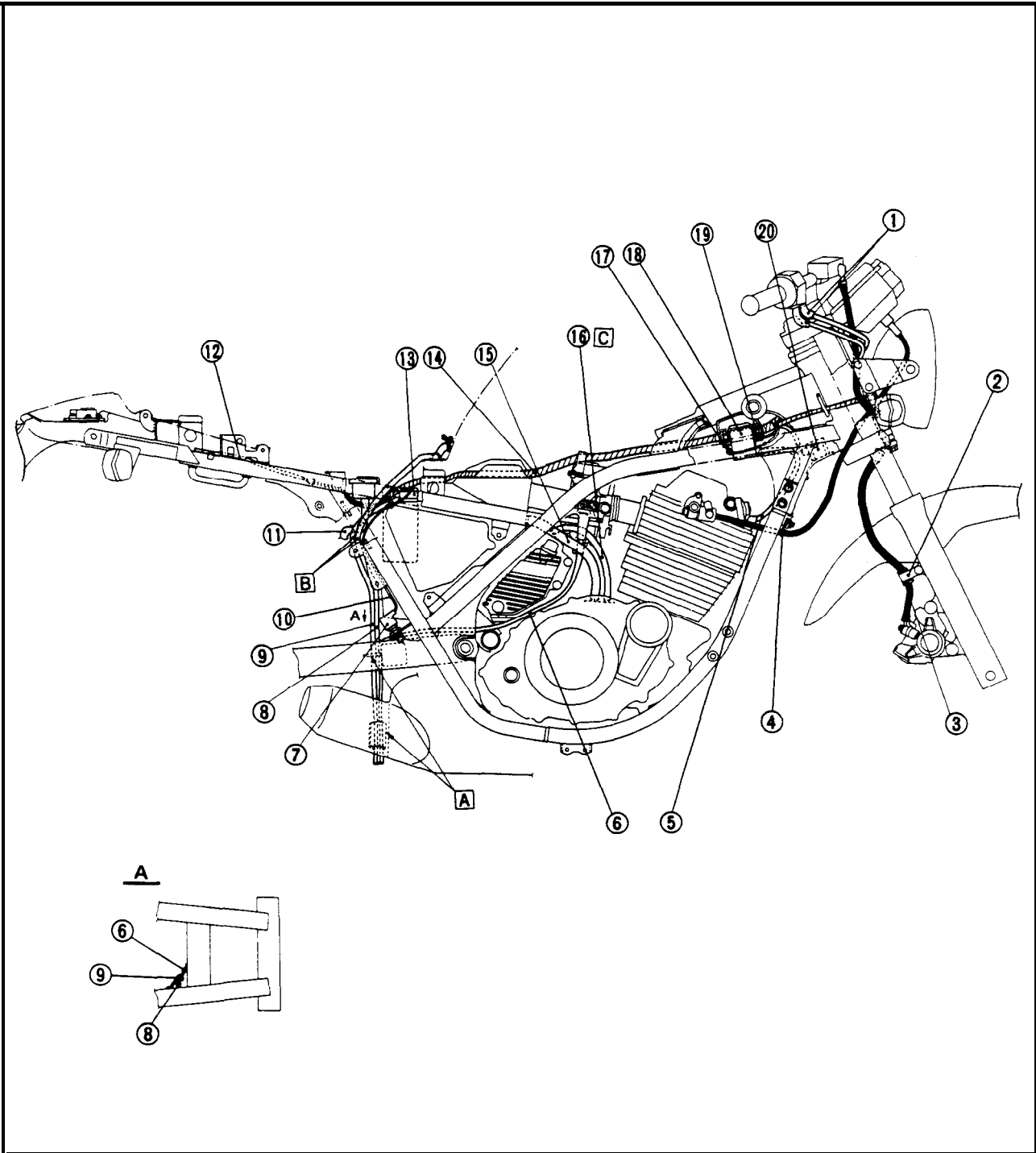

**7**

# CABLE ROUTING



- ① Clamp
- ② Wire harness
- ③ Band
- ④ Throttle cables
- ⑤ Starter cable
- ⑥ Air vent hose
- ⑦ Rectifier/Regulator lead
- ⑧ CDI unit
- ⑨ CDI unit lead
- ⑩ Oil tank hose
- ⑪ Clutch cable
- ⑫ Speedometer cable
- ⑬ Brake hose
- Pass the hoses at the back of the oil tank.
- Pass the speedometer cable into the cable holder.

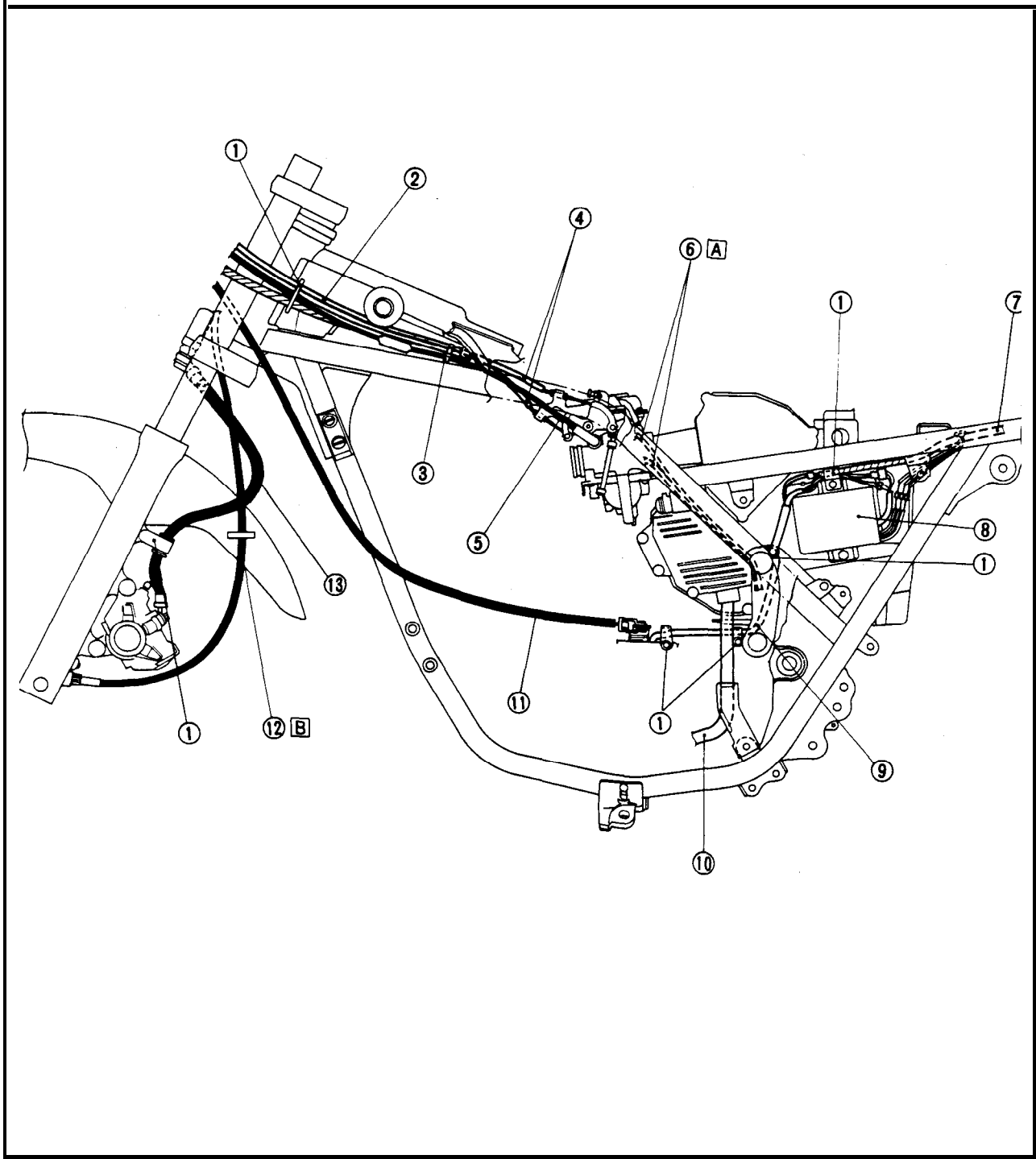

7

- |                                   |                             |   |
|-----------------------------------|-----------------------------|---|
| ① Horn                            | ⑨ Rectifier/Regulator       | • J White taping:<br>Match the white tape to the main pipe end. |
| ② Clamp                           | ⑩ Rear flasher light (Left) | ⓑ Pass the lead between the mud guard and frame.                |
| ③ Carburetor                      | ⑪ To CDI unit lead          |   |
| ④ Wire harness                    | ⑫ To CDI unit               |   |
| ⑤ Battery positive lead           | ⑬ Circuit breaker           |   |
| ⑥ Brake reservoir tank            | ⑭ Battery negative lead     |   |
| ⑦ Rear flasher light lead (Right) | ⑮ Fuel tank breather hose   |   |
| ⑧ Taillight lead                  |                             |   |

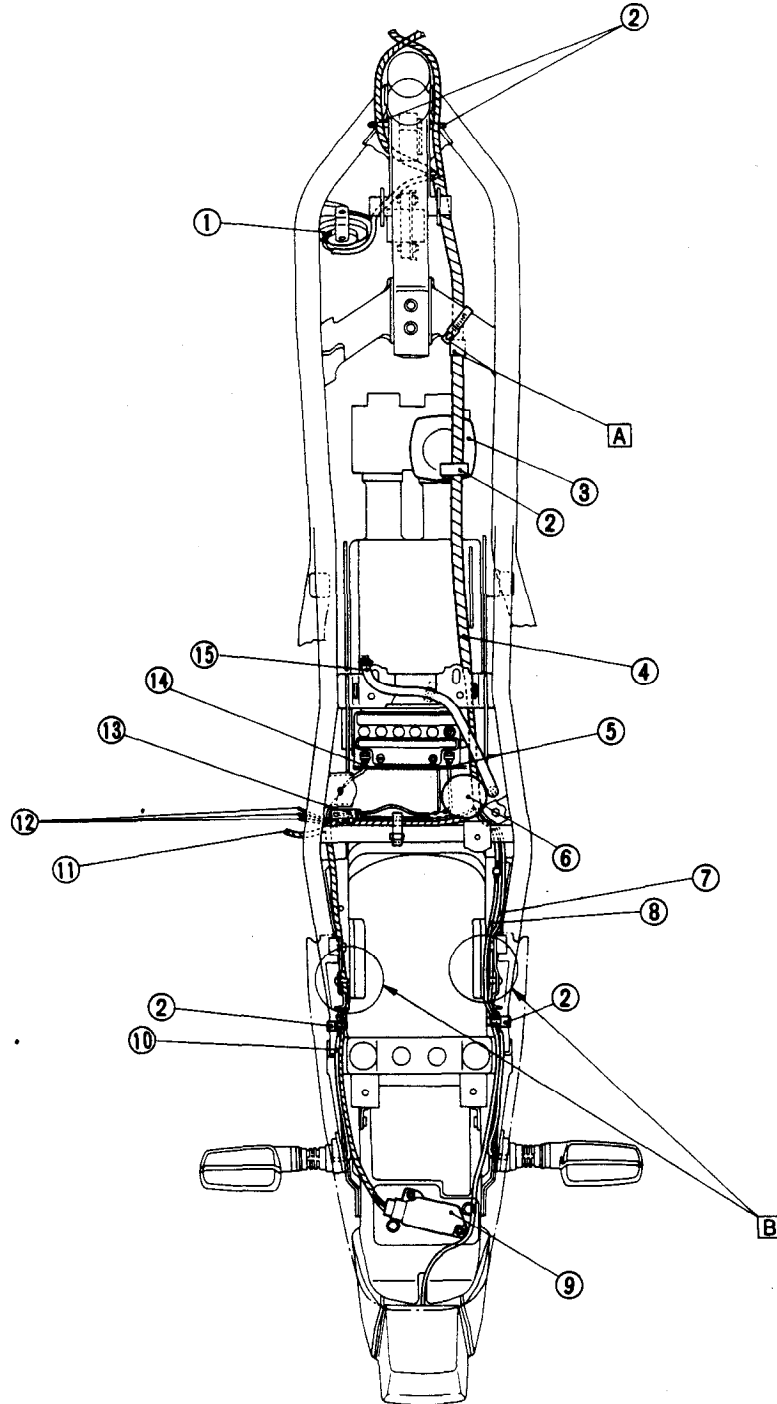

**7**