



YAMAHA

SRX600

OWNER'S MANUAL

1XR-28199-W0

IDENTIFICATION NUMBERS RECORD

1. KEY NUMBER:

2. FRAME NUMBER AND ENGINE NUMBER:

Your key identification number is stamped on your key as shown in the following illustration

Record this number in the space provided for reference if you need a new key.

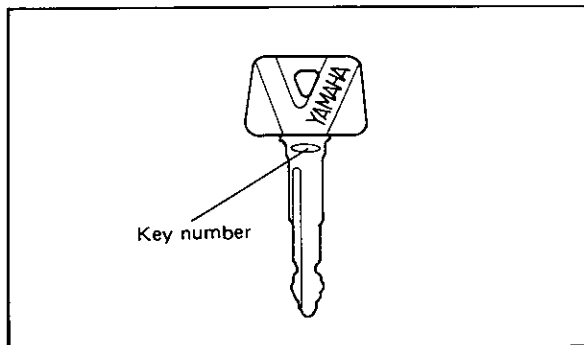

Record your frame and engine number in the spaces provided to assist you in ordering spare parts from your Yamaha dealer or for reference in case your vehicle is stolen. (See page 2-1)

A-001

SRX600

OWNER'S MANUAL

©1985 by Yamaha Motor Co., Ltd.

1st Edition, December 1985

**All rights reserved. Any reprinting or
unauthorized use without the written
permission of Yamaha Motor Co., Ltd.
is expressly prohibited.**

Printed in Japan

INTRODUCTION

Congratulations on your purchase of the Yamaha SRX600. This model is the result of Yamaha's vast experience in the production of fine sporting, touring, and pacesetting racing machines. It represents the high degree of craftsmanship and reliability that have made Yamaha a leader in these fields.

This manual will give you an understanding of the operation, inspection, and basic maintenance of this motorcycle. If you have any questions about the operation or maintenance of your motorcycle, please consult a Yamaha dealer.

NOTE: _____

Some data in this manual may become outdated due to future improvement on this model. If you have any questions about this manual or your motorcycle, please consult a Yamaha dealer.

**TECHNICAL PUBLICATIONS
SERVICE DIVISION
MOTORCYCLE OPERATIONS
YAMAHA MOTOR CO., LTD.**

WARNING: _____

PLEASE READ THIS MANUAL CAREFULLY AND COMPLETELY BEFORE OPERATING THIS MOTORCYCLE.

Particularly important information is distinguished in this manual by the following notations:

NOTE:

A NOTE provides key information to make procedures easier or clearer

CAUTION:

A CAUTION indicates special procedures that must be followed to avoid damage to the motorcycle

WARNING:

A WARNING indicates special procedures that must be followed to avoid injury to a motorcycle operator or person inspecting or repairing the motorcycle

U-000

NOTE: _____

This manual should be considered a permanent part of this motorcycle and should remain with it even if the motorcycle is subsequently sold.

CONTENTS

DESCRIPTION	1-1	Kick starter	3-8
MOTORCYCLE IDENTIFICATION ..	2-1	Steering lock.	3-9
Frame serial number.	2-1	Seat lock	3-10
Engine serial number.....	2-1	Helmet holder	3-11
CONTROL FUNCTIONS... ..	3-1	Rear shock absorber	3-12
Main switch.	3-1	PRE-OPERATION CHECKS	4-1
Indicator lights	3-2	Brakes..	4-3
Speedometer	3-2	Brake fluid leakage.....	4-3
Tachometer.	3-3	Clutch.....	4-4
Handlebar switches..	3-4	Throttle grip	4-4
Clutch lever	3-5	Engine oil	4-4
Change pedal	3-5	Chain	4-5
Front brake lever	3-6	Tires	4-5
Rear brake pedal.....	3-6	Tubeless tires and cast wheels	4-7
Fuel tank cap	3-6	Fittings/Fasteners.	4-9
Fuel cock.	3-7	Lights and signals	4-9
Starter lever (CHOKE)..	3-8	Switches	4-9
		Battery	4-9

Fuel...	4-9	Throttle cable adjustment.	6-14
Fuel tank breather hose...	4-10	Valve clearance adjustment	6-15
OPERATION AND IMPORTANT		Decompression cable adjustment	6-15
RIDING POINTS		Spark plug inspection	6-16
Starting and warming up	5-1	Front brake adjustment	6-17
a cold engine	5-1	Rear brake adjustment	6-18
Starting a warm engine	5-2	Brake light switch adjustment	6-19
Shifting	5-2	Checking the front and	
Engine break-in	5-3	rear brake pads	6-19
Parking	5-4	Inspecting the brake fluid level	6-20
PERIODIC MAINTENANCE AND		Brake fluid replacement	6-21
MINOR REPAIR		Clutch adjustment	6-21
Tool kit	6-1	Free play adjustment	6-22
Periodic maintenance/Lubrication	6-3	Drive chain slack check	6-22
Torque specifications	6-6	Drive chain slack adjustment	6-23
Engine oil	6-7	Drive chain lubrication	6-24
Fuel cock cleaning	6-11	Cable inspection and lubrication	6-25
Air filter	6-11	Throttle cable and grip lubrication	6-25
Carburetor adjustment	6-13	Brake and change pedals	6-25
Idle speed adjustment	6-13	Brake and clutch levers	6-26
		Sidestand	6-26
		Rear suspension	6-26

WIRING DIAGRAM

Front fork oil change.....	6-26
Rear shock absorber adjustment.....	6-29
Steering inspection	6-29
Wheel bearings..	6-30
Battery	6-30
Replenishing the battery fluid	6-32
Circuit breaker	6-33
Replacing the headlight bulb.....	6-34
Headlight beam adjustment	6-35
Front wheel removal	6-36
Front wheel installation.....	6-38
Rear wheel removal	6-39
Rear wheel installation	6-41
Troubleshooting	6-41
Troubleshooting chart.....	6-43

CLEANING AND STORAGE	7-1
Cleaning	7-1
Storage	7-2
Noise regulation (for Australia)	7-3

SPECIFICATIONS	8-1
------------------------	-----

DESCRIPTION

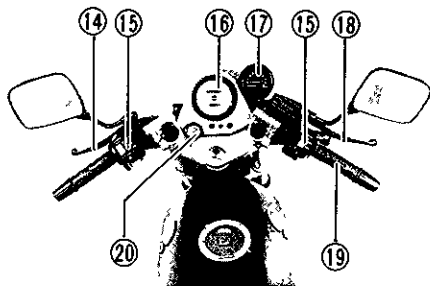
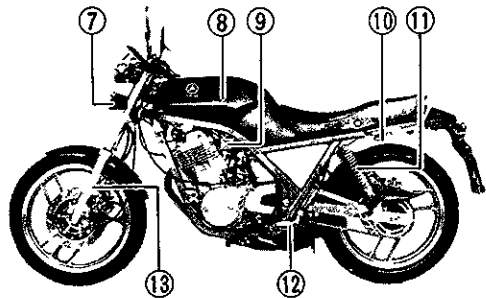
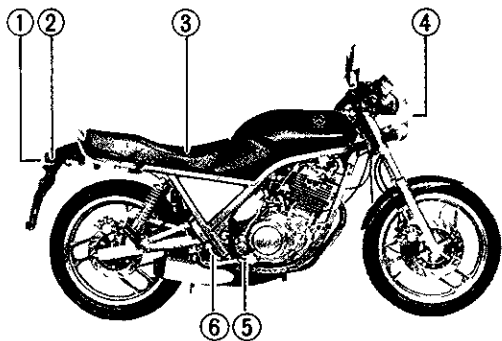

- | | |
|-----------------------|------------------------|
| 1 Tail/Brake light | 11 Rear shock absorber |
| 2 Rear flasher light | 12 Change pedal |
| 3 Seat | 13 Front fork |
| 4 Headlight | 14 Clutch lever |
| 5 Brake pedal | 15 Handlebar switch |
| 6 Footrest | 16 Speedometer |
| 7 Front flasher light | 17 Tachometer |
| 8 Fuel tank | 18 Brake lever |
| 9 Fuel cock | 19 Throttle grip |
| 10 Helmet holder | 20 Main switch |

A-600

MOTORCYCLE IDENTIFICATION

A-602

Frame serial number

The frame serial number is stamped into the right side of the steering head pipe.

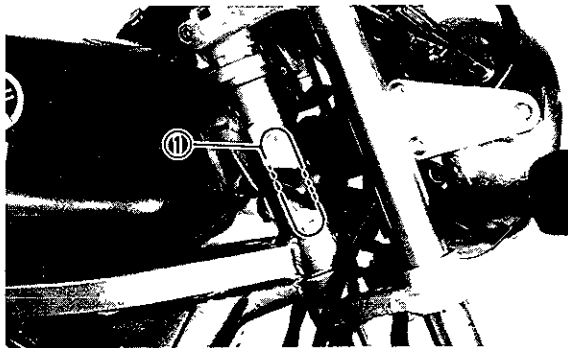

1 Frame serial number

A-701

Engine serial number

The engine serial number is stamped into the right side of the engine.

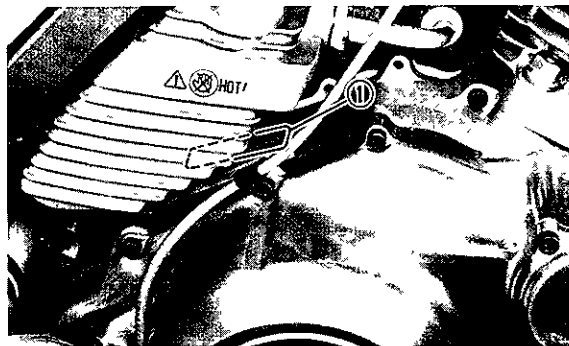

1 Engine serial number

U-003

NOTE: _____

The first three digits of these numbers are for model identification, the remaining digits are the unit production number. Keep a record of these numbers for reference when ordering parts from a Yamaha dealer

B-000

CONTROL FUNCTIONS

B-001

Main switch

The main switch controls the ignition and lighting systems; its operation is described below

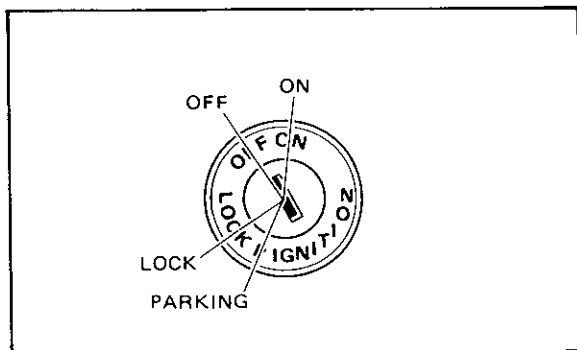

U-005

NOTE:

On this model the main switch comes in two types, one with a steering lock device and the other without it.

B-005

ON.

Electrical circuits are switched on. The engine can be started. The key cannot be removed in this position.

B-006

OFF

All electrical circuits are switched off. The key can be removed in this position.

B-007

LOCK.

The steering is locked in this position, and all electrical circuits are switched off. The key can be removed in this position. Refer to "Steering lock" (Page 3-9) for proper operation.

B-012

PARKING

The steering is locked in this position, and the taillight and auxiliary light come on but all other circuits are off. The key can be removed in this position.

NOTE: _____
 Always turn the main switch to "OFF" or "LOCK" and remove the key when the motorcycle is unattended

Indicator lights

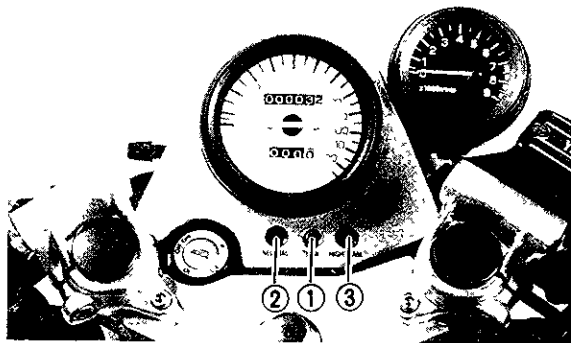

- 1 "TURN" indicator light
- 2 "NEUTRAL" indicator light
- 3 "HIGH BEAM" indicator light

"TURN" indicator light (orange):

This indicator flashes when the turn switch is "ON".

"NEUTRAL" indicator light (green)

This indicator comes on when the transmission is in neutral.

"HIGH BEAM" indicator light (blue):

This indicator comes on when the headlight high beam is used

Speedometer

The odometer and trip odometer are built into the speedometer. The trip odometer can be reset to "O" with the reset switch.

Use the odometer to estimate how far you can ride on a tank of fuel before going to "RESERVE". This information will enable you to plan fuel stops in the future.

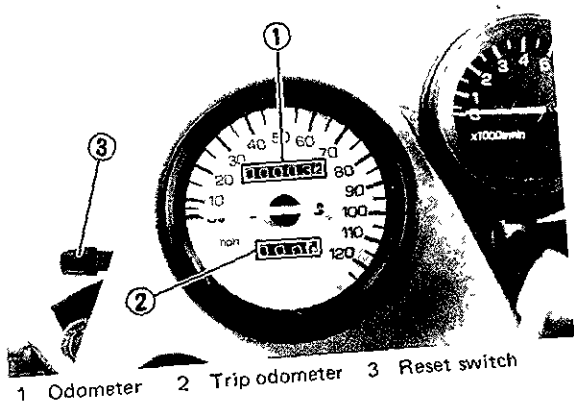

1 Odometer 2 Trip odometer 3 Reset switch

B-403

Tachometer

This model is equipped with a tachometer so the rider can monitor the engine speed and keep it within the ideal power range.

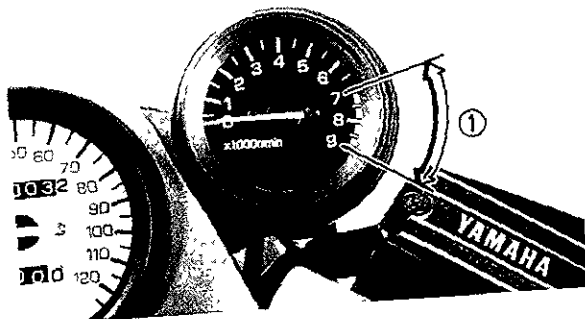

1 Red zone

U-304

CAUTION:

Do not operate in the red zone
 Red zone: 7,000 r/min and above

Handlebar switches:

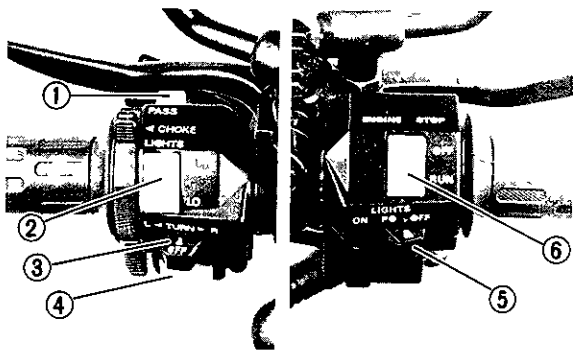

- | | |
|----------------------------|------------------------|
| 1 "PASS" switch | 5 "LIGHTS" switch |
| 2 "LIGHTS" (Dimmer) switch | 6 "ENGINE STOP" switch |
| 3 "TURN" switch | |
| 4 "HORN" switch | |

B-610

"PASS" switch

When you are passing a vehicle ahead, the passing light switch should be depressed so that the headlight gives a signal to the rider

B-601

"LIGHTS" (Dimmer) switch

Turn the switch to "HI" for the high beam and to "LO" for the low beam

B-604

"TURN" signal switch

This model comes with one of two types of turn signals self-cancelling (A) and manual (B)

- A. To signal a right-hand turn, push the switch to the right; to signal a left hand turn, push the switch to the left.

Once the switch is released it will return to the center position. To cancel the signal, push the switch in after it has returned to the center position. If the switch is not cancelled by hand, it will self-cancel after the motorcycle has travelled for 10 seconds or 150 meters (490 feet) whichever is greater.

The self-cancelling mechanism only operates when the motorcycle is moving, thus the signal will not self-cancel while you are stopped at an intersection.

B To signal a right-hand turn, push the switch to the right; to signal a left-hand turn, push the switch to the left. Once the switch is released it will return to the center position. To cancel the signal, push the switch in after it has returned to the center position.

8-602

“HORN” switch

Press the switch to sound the horn.

8-612

“LIGHTS” switch

Turn the light switch to “ON” to turn on the headlight, taillight, and meter lights. Turn the light switch to “PO” to turn on the auxiliary light, taillight, and meter lights.

8-609

“ENGINE STOP” switch

The engine stop switch is a safety device for use in an emergency such as when the motorcycle overturns or when trouble occurs in the throttle system. The engine will not run when the engine stop switch is turned to “OFF.” In case of emergency, turn the switch to “OFF.”

8-701

Clutch lever

The clutch lever is located on the left handlebar; it disengages or engages the clutch. Pull the clutch lever to the handlebar to disengage the clutch, and release the lever to engage the clutch. The lever should be pulled rapidly and released slowly for smooth starts.

8-800

Change pedal

The gear ratios of the constant-mesh 5-speed transmission are ideally spaced. The gears can be shifted by using the change pedal on the left side of the engine.

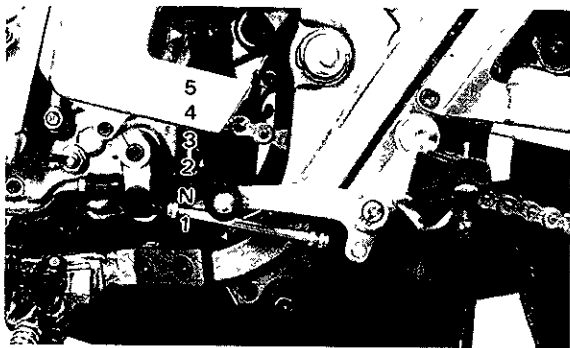

N Neutral

B-900

Front brake lever

The front brake lever is located on the right handlebar. Pull it toward the handlebar to activate the front brake.

B-901

Rear brake pedal

The rear brake pedal is on the right side of the motorcycle. Press down on the brake pedal to activate the rear brake.

C-005

Fuel tank cap

TO OPEN:

Open the key cover. Insert the key and turn clockwise 1/4 turn. The lock will be released and the cap can be opened.

TO CLOSE:

Push the tank cap into position with the key inserted. To remove the key, turn it counter-clockwise to the original position. Then, close the key cover.

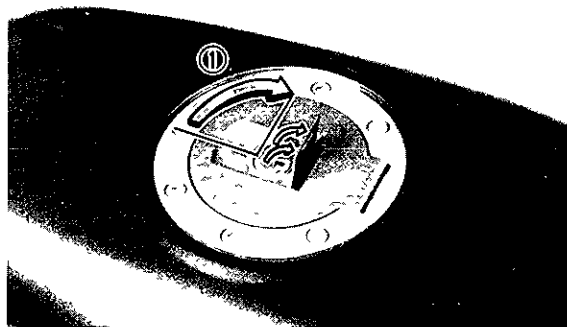

1 Open

NOTE: _____

This tank cap cannot be closed unless the key is in the lock. The key cannot be removed if the cap is not locked properly.

Fuel cock

The negative pressure fuel cock supplies fuel from the tank to the carburetors and also filters the fuel. The fuel cock has the following three positions:

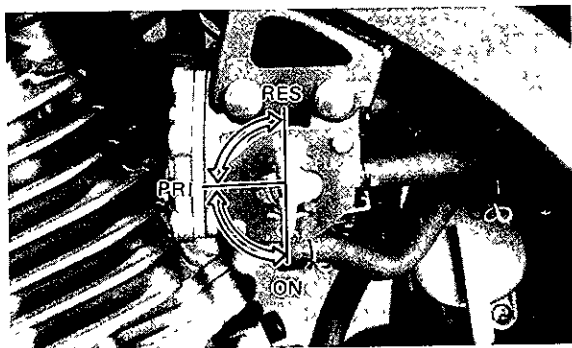

- ON.** With the lever in this position, fuel flows if the engine is running but stops if the engine is not running
- RES** This indicates reserve. If you run out of fuel while riding, move the lever to "PRI", start the engine, then switch to "RES". FILL THE TANK AT THE FIRST OPPORTUNITY. BE SURE TO SET THE LEVER TO "ON" AFTER REFUELING

NOTE: _____

The fuel cock operates on vacuum from the engine when set at "ON" or "RES." If the line connecting the cock to the carburetor intake manifold is not connected or has a leak, the cock will not function properly

PRI. This indicates prime. With the lever in this position, fuel flows whether the engine is running or not. If the fuel tank is completely empty, refill the tank, prime the carburetor in this position, and then switch to "ON" after starting the engine.

C-204

Starter lever (CHOKE)

When cold, the engine requires a richer air-fuel mixture for starting. A separate starter circuit supplies this mixture. The starter on this model is a 2-position type.

- 1 Turn the lever projection fully toward you
 - When starting a cold engine
- 2 Turn the lever projection half-way back
 - When warming up the engine

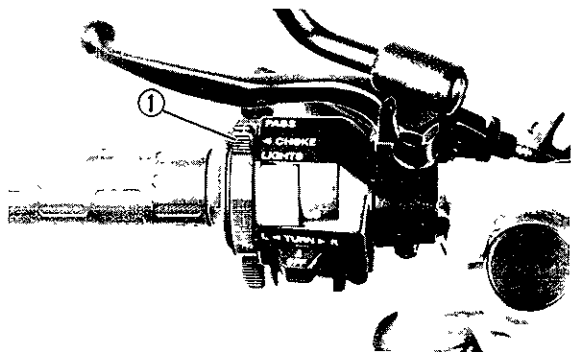

1 Starter lever (CHOKE)

U-016

NOTE: _____
Refer to "Starting and warming up a cold engine" for proper operation.

C-603

Kick starter

Rotate the kick starter away from the engine. Push the starter down lightly with your foot until the gears engage, then kick smoothly and forcefully to start the engine. This model

has a primary-coupled kick starter so the engine can be started in any gear if the clutch is disengaged. In normal practice, however, shift to neutral before starting.

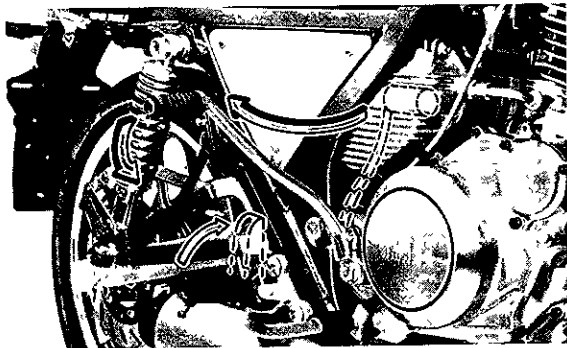

U-067

NOTE: _____

This model features an autodecomp. device, which frees the operator from the trouble otherwise required

C-300

Steering lock

The steering is locked when the main switch is turned to "LOCK." To lock the steering, turn the handlebars all the way to the left or right. With the key at "OFF," push it into the main switch, turn the key counterclockwise to "LOCK," and remove the key. To release the lock, turn the key clockwise.

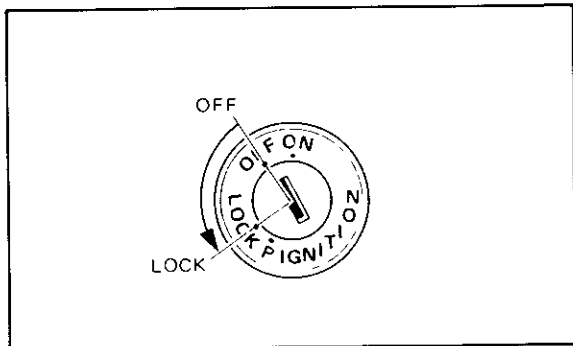

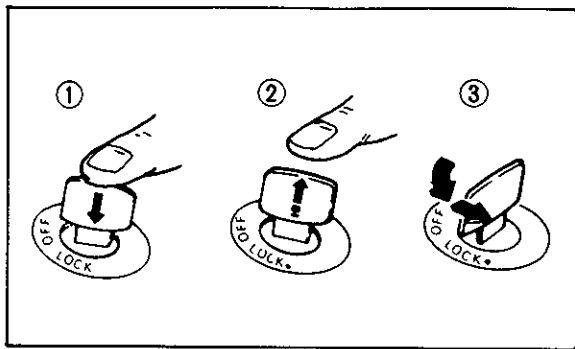

1 Push

2 Release

3 Turn

U-614

WARNING:

Never turn the key to "LOCK" when the motorcycle is moving.

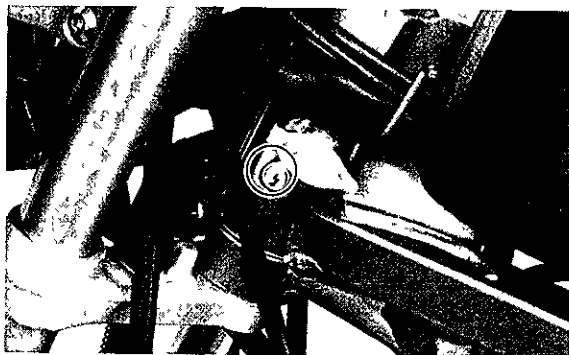

C-403

Seat lock

To open the seat lock, turn the key as shown
To lock the seat, remove the key and install the seat in its original position

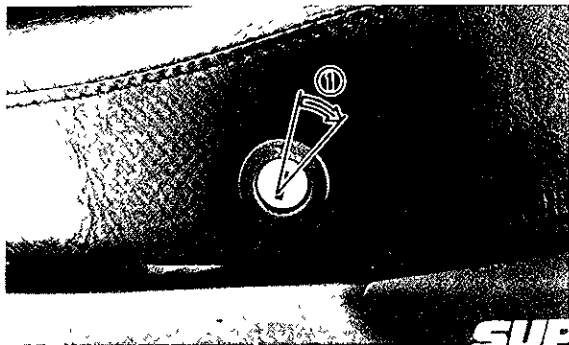

1 Open

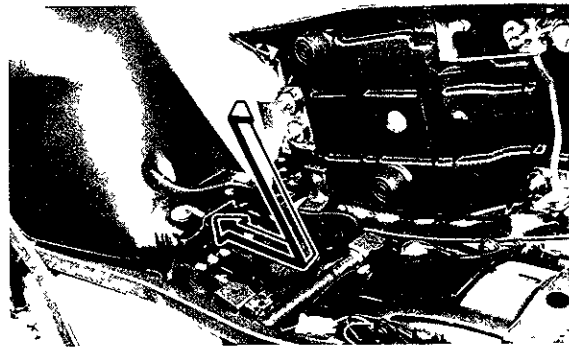

C-500

Helmet holder

To open the helmet holder, insert the key in the lock and turn it as shown. To lock the helmet holder, replace the holder in its original position.

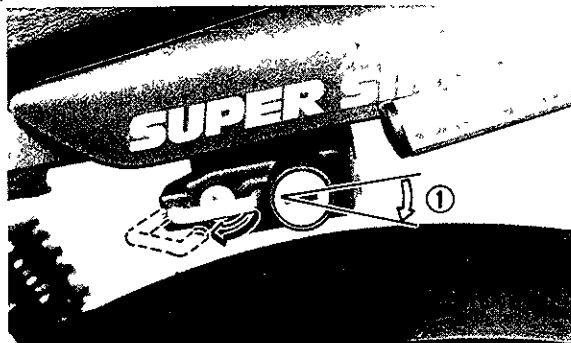

1 Open

U-615

WARNING:

Never ride with a helmet in the helmet holder. It could interfere with rear wheel movement, causing loss of control and possibly an accident.

Rear shock absorber

The spring preload of the rear shock absorber can be adjusted to suit motorcycle's load (ex optional accessories etc.) and riding conditions. Refer to page 6-29 for proper adjustment procedures.



PRE-OPERATION CHECKS

Before using this motorcycle, check the following points

Item	Routine	Page
Front and rear brakes	Check operation, free play, fluid level, and fluid Leakage Top-up with DOT #3 brake fluid if necessary	4-3~4-4 6-17~6-21
Clutch	Check operation, condition and free play Adjust if necessary	4-4, 6-21
Throttle grip/Housing	Check for smooth operation Lubricate/Adjust if necessary	4-4, 6-25
Engine oil	Check oil level/add oil as required.	4-4, 6-7~6-11
Drive chain	Check chain slack and condition. Adjust if necessary	4-5, 6-23~6-24
Wheels/Tires	Check tire pressure, wear, damage	4-5~4-9, 6-36~6-41
Control/Meter cable	Check for smooth operation Lubricate if necessary	6-25
Brake and change pedal shafts	Check for smooth operation Lubricate if necessary	6-25
Brake and clutch lever pivots	Check for smooth operation Lubricate if necessary	6-26
Sidestand pivot	Check for smooth operation Lubricate if necessary	6-26
Fittings/Fasteners	Check all chassis fittings and fasteners Tighten/Adjust, if necessary	4-9, 6-6
Fuel tank	Check fuel level/top-up as required	4-9~4-10
Lights and signals	Check for proper operation	4-9
Battery	Check fluid level, top-up with distilled water if necessary	4-9, 6-30~6-33

NOTE:

Pre-operation checks should be made each time the motorcycle is used. Such an inspection can be thoroughly accomplished in a very short time, and the added safety it assures is more than worth the time involved

WARNING:

If any item in the Pre-Operation Check is not working properly, have it inspected and repaired before operating the motorcycle.

Brakes (See page 6-17 for more detail)**1 Brake lever and brake pedal**

Check for correct free play in the front brake lever and rear brake pedal. Make sure they are working properly. Check the brakes at low speed shortly after starting out. If the free play is incorrect, adjust it.

WARNING:

A soft, spongy feeling in the brake lever (and/or brake pedal) indicates a failure in the brake system. Do not operate the motorcycle until the failure in the brake system is corrected. Ask a Yamaha dealer for immediate repairs. A soft, spongy feeling could indicate a hazardous condition in the brake system.

2 Brake fluid

Check the brake fluid level.
Add fluid if necessary

Recommended brake fluid: DOT#3

3. Check the disc pads.

Refer to page 6-19.

NOTE:

When this brake service is necessary, ask a Yamaha dealer.

Brake fluid leakage

Apply each brake for a few minutes. Check to see if any brake fluid leaks out from the pipe joints or the master cylinder(s)

WARNING:

If brake fluid leakage is found, ask a Yamaha dealer for immediate repairs. Such leakage could indicate a hazardous condition.

Clutch (See page 6-21 for more detail)

Check the free play in the clutch lever, and make sure the lever operates properly. If the free play is incorrect, adjust it.

Throttle grip (See page 6-25 for more detail)

Turn the throttle grip to see if it operates properly, and check the free play. Make sure the grip returns by spring force when released. Ask a Yamaha dealer to make any necessary adjustments.

Engine oil (See page 6-7 for more detail)

Make sure the engine oil is at the specified level. Add oil as necessary.

Recommended oil.

SAE 20W40 type SE motor oil

Oil capacity.

Total.

2.4 L(2.1 Imp qt, 2.5 US qt)

Periodic oil change

2.0 L(1.8 Imp qt, 2.1 US qt)

With oil filter replacement.

2.1 L(1.8 Imp qt, 2.2 US qt)

Oil tank capacity

1.8 L(1.6 Imp qt, 1.9 US qt)

NOTE:

Recommended engine oil classification, API Service "SE", "SF" type or equivalent (e.g. "SF-SE", "SF-SE-CC", "SF-SE-SD" etc.).

Chain (See page 6-22 for more detail)

Check the general condition of the chain and check the chain slack before every ride. Lubricate and adjust the chain as necessary.

Tires

To ensure maximum performance, long service, and safe operation, note the following

- 1 Tire air pressure

Always check and adjust the tire pressure before operating the motorcycle.

WARNING:

Tire inflation pressure should be checked and adjusted when the temperature of the tire equals the ambient air temperature. Tire inflation pressure must be adjusted according to total weight of cargo, rider, passenger, and accessories (fairing, saddlebags, etc. if approved for this model), and vehicle speed.

Basic weight With oil and full fuel tank	176 kg (388 lb)	
Maximum load*	204 kg (450 lb)	
Cold tire pressure	Front	Rear
Up to 90kg (198 lb) load*	177 kPa (18 kg/cm ² , 26 psi)	196 kPa (20 kg/cm ² , 28 psi)
90 kg (198 lb) ~ Maximum load*	196 kPa (20 kg/cm ² , 28 psi)	226 kPa (23 kg/cm ² , 32 psi)
High speed riding	196 kPa (20 kg/cm ² , 28 psi)	226 kPa (23 kg/cm ² , 32 psi)

* Load is the total weight of cargo, rider, passenger, and accessories

WARNING:

Proper loading of your motorcycle is important for the handling, braking, and other performance and safety characteristics of your motorcycle. Do not carry loosely packed items that can shift. Securely pack your heaviest

items close to the center of the motorcycle, and distribute the weight evenly from side to side. Properly adjust the suspension for your load, and check the condition and pressure of your tires. **NEVER OVERLOAD YOUR MOTORCYCLE.** Make sure the total weight of the cargo, rider, passenger, and accessories (fairing, saddlebags, etc. if approved for this model) does not exceed the maximum load of the motorcycle. Operation of an overloaded motorcycle could cause tire damage, an accident, or even injury.

2 Tire inspection

Always check the tires before operating the motorcycle. If a tire tread shows crosswise lines (minimum tread depth), if the tire has a nail or glass fragments in it, or if the side wall is cracked, contact a Yamaha dealer immediately and have him replace the tire.

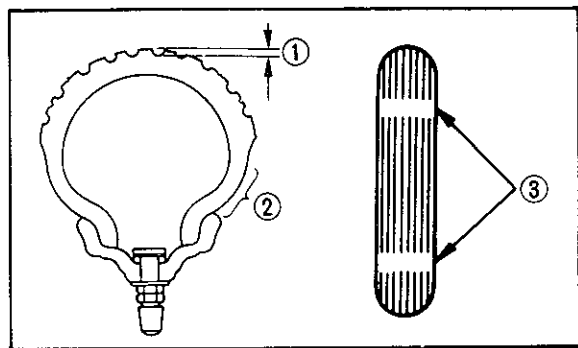

1 Tread depth 2 Side wall 3 Wear indicator

U-678

WARNING:

After extensive tests, the tires mentioned below have been approved by Yamaha motor Co., Ltd. for this model. No guarantee for handling characteristics can be given if tire combinations other than what is approved are used on this motorcycle.

The front and rear tires should be of the same manufacture and design.

CE9-02

FRONT

Manufacture	Size	Type
Bridgestone	100/80 18-53S	YKD
Yokohama	100/80 18-53S	PO41M
Metzeler (for spain)	100/80 18-53S	ME33

REAR

Manufacture	Size	Type
Bridgestone	120/80 18-62S	KJK
Yokohama	120/80 18-62S	PO41G
Metzeler (for spain)	120/80 18-62S	ME99A

Minimum tire tread depth (front and rear)	1.0 mm (0.04 in)
---	------------------

U-679

WARNING:

It is dangerous to ride with a worn-out tire. When a tire tread begins to show lines. Have a Yamaha dealer replace the tire immediately. Brakes, tires, and related wheel parts replacement should be left to a Yamaha Service Technician.

E-938

Tubeless tires and cast wheels

This motorcycle is equipped with cast wheels designed for either tube or tubeless tires. Tubeless tires are installed as standard equipment.

U-686

WARNING:

Do not attempt to use tubeless tires on a wheel designed for use only with tube-type tires. Tire failure and personal injury may result from sudden deflation.

Tube-type Wheel

→ Tube-type Tires only

Tubeless-type Wheel

→ Tube-type or Tubeless tires

U-687

WARNING:

When using tube-type tires, be sure to install the proper tube also.

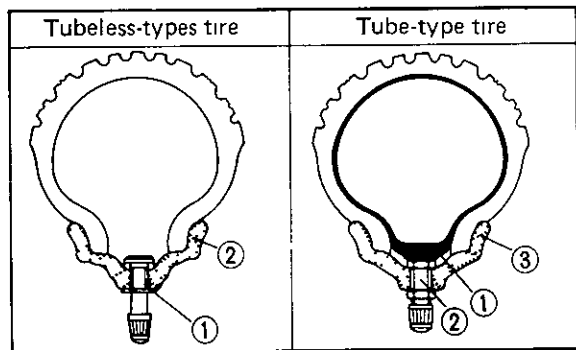
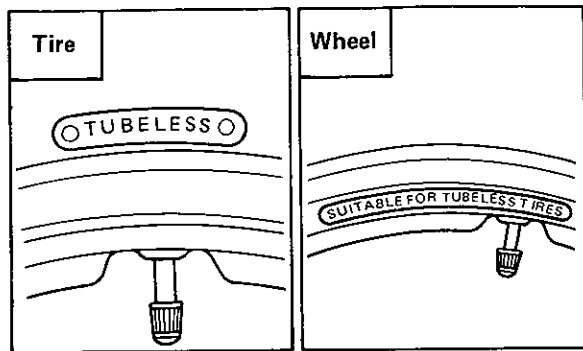

1 Air valve

2 Cast wheel (Tubeless wheel)

1 Tube

2 Air valve

3 Cast wheel

To ensure maximum performance, long service, and safe operation, note the following

1. Always inspect the wheels before a ride. Check for cracks, bends, or warpage of the wheels. If any abnormal condition exists in a wheel, consult a Yamaha dealer. Do not attempt even small repairs to the wheel. If a wheel is deformed or cracked, it must be replaced.
2. Tires and wheels should be balanced whenever either one is changed or replaced. Failure to have a wheel balanced can result in poor performance, adverse handling characteristics, and shortened tire life.
3. After installing a tire, ride conservatively to allow the tire to seat itself on the rim properly. Failure to allow proper seating may cause tire failure, resulting in damage to the motorcycle and injury to the rider.

- 4 After repairing or replacing a tire, check to be sure the valve stem lock nut is securely fastened. If not, torque it as specified

Tightening torque

1.5 Nm (0.15 m·kg, 1.1 ft·lb)

E-850

Fittings/Fasteners

Always check the tightness of chassis fittings and fasteners before a ride. Use the chart on page 6-6 to find the correct torque.

E-700

Lights and signals

Check the headlight, flasher lights, taillight, brake light, meter lights, and all the indicator lights to make sure they are in working condition

E-704

Switches

Check the operation of the headlight switch, turn switch, brake light switch, horn switch, main switch, etc.

E-705

Battery (See page 6-30 for more detail)

Check the fluid level and top-up if necessary. Use only distilled water if refilling is necessary.

E-800

Fuel

Make sure there is sufficient fuel in the tank.

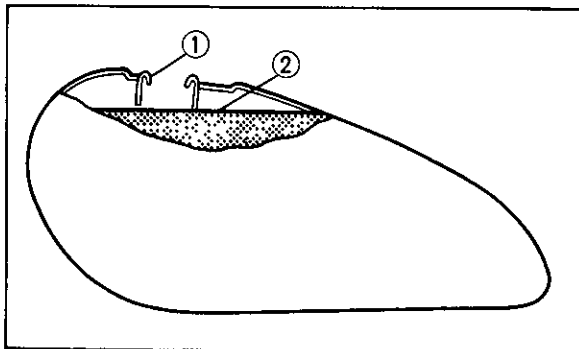

1 Filler tube

2 Fuel level

WARNING:

Do not overfill the fuel tank. Avoid spilling fuel on the hot engine. Do not fill the fuel tank above the bottom of the filler tube as shown in the illustration or it may overflow when the fuel heats up later and expands.

E-803

Recommended fuel	Regular gasoline
For Australia	Unleaded fuel only
Fuel tank capacity	
Total	
15 L (3.3 Imp gal, 4.0 US gal)	
Reserve	
3 L (0.7 Imp gal, 0.8 US gal)	

E-808

Fuel tank breather hose

This model is equipped with the fuel tank breather hose. Before using this motorcycle be sure to check the following:

1. Check hose connection.
2. Check hose for cracks or damage. Replace if damaged.
3. Make sure the bottom hose is not blocked. Clean it if necessary.

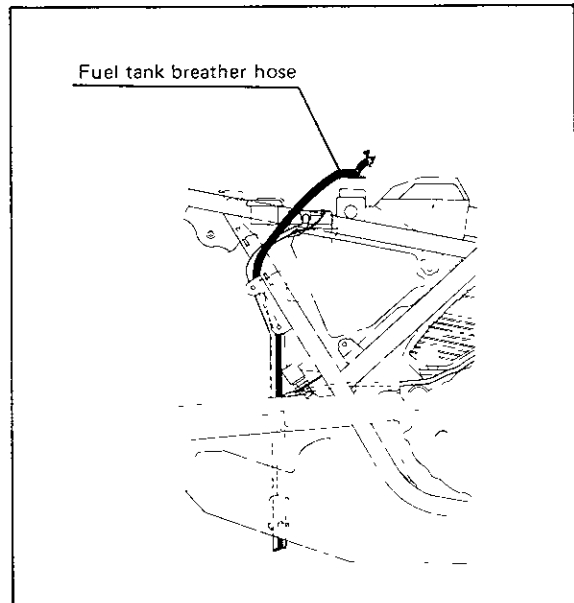

OPERATION AND IMPORTANT RIDING POINTS

U-672

WARNING:

Before riding this motorcycle, become thoroughly familiar with all operating controls and their function. Consult a Yamaha dealer regarding any control or function that you do not thoroughly understand.

U-628

WARNING:

1. Never start your engine or let it run for any length of time in a closed area. The exhaust fumes are poisonous and can cause loss of consciousness and death within a short time. Always operate your motorcycle in an area with adequate ventilation.

2. Before starting out, always be sure the sidestand is up. Failure to retract the sidestand completely can result in a serious accident when you try to turn a corner.

F-135K

Starting and warming up a cold engine

1. Turn the fuel cock to "ON."
2. Turn the ignition key to "ON" and the engine stop switch to "RUN."
3. Shift transmission into neutral.

U-030

NOTE:

When the transmission is in neutral, the neutral indicator light (green) should be on. If the light does not come on, ask a Yamaha dealer to inspect it

4. Fully open the starter (CHOKE) and completely close the throttle grip.

5. Kick the kick starter to start the engine.
6. After starting the engine, turn back the starter (CHOKE) to warming up position (about halfway)

U-026

NOTE: _____

To get maximum engine life, always warm up the engine before starting off. Never accelerate hard with a cold engine!

7. After warming up the engine, turn off the starter completely

U 027

NOTE: _____

The engine is warm when it responds normally to the throttle with the starter turned off

F-108

Starting a warm engine

The starter (CHOKE) is not required when the engine is warm

U-314

CAUTION _____

See "Break-in section" prior to operating the motorcycle for the first time.

F-200

Shifting

The transmission lets you control the amount of power you have available at a given speed for starting, accelerating, climbing hills, etc. The use of the change pedal is shown in the illustration (Page 3-5)

To shift into NEUTRAL, depress the change pedal repeatedly until it reaches the end of its travel (you will feel a stop when you are in first gear) then raise the pedal slightly

CAUTION:

- 1. Do not coast for long periods with the engine off, and do not tow the motorcycle a long distance. Even with gears in neutral, the transmission is only properly lubricated when the engine is running. Inadequate lubrication may damage the transmission.**
 - 2. Always use the clutch when changing gears. The engine, transmission, and driveline are not designed to withstand the shock of forced shifting and can be damaged by shifting without the clutch.**
-

Engine break-in

There is never a more important period in the life of your motorcycle than the period between zero and 1,000 km (600 mi). For this reason we ask that you carefully read the following material. Because the engine is brand new, you must not put an excessive load on it for the first 1,000 km (600 mi). The various parts in the engine wear and polish themselves to the correct operating clearances. During this period, prolonged full throttle operation or any condition which might result in excessive heating of the engine, must be avoided.

- 1 0 ~ 150 km (0 ~ 90 mi):**

Avoid operation above 4,000 r/min. Stop the engine and let it cool for 5 to 10 minutes after every hour of operation. Vary the speed of the motorcycle from time to time. Do not operate it at one set throttle position.

- 2 150 ~ 500 km (90 ~ 300 mi)
Avoid prolonged operation above 5,000 r/min. Rev the motorcycle freely through the gears, but do not use full throttle at any time.
3. 500 ~ 1,000 km (300 ~ 600 mi).
Avoid prolonged full throttle operation
Avoid cruising speeds in excess of 6,000 r/min

U-372

CAUTION:

After 1,000 km (600 mi) of operation, be sure to replace the engine oil and oil filter element, and clean the oil strainer.

- 4 1,000 km (600 mi) and beyond
Full throttle can be used

U-387

CAUTION:

Never let engine speeds enter the red zone.

U-322

CAUTION:

If any engine trouble should occur during the break-in period, consult a Yamaha dealer immediately.

F-400

Parking

When parking the motorcycle, stop the engine and remove the ignition key

U-630

WARNING:

The muffler and exhaust pipe are hot. Park the motorcycle in a place where pedestrians or children are not likely to touch the motorcycle.

Do not park the motorcycle on a slope or soft ground; the motorcycle may overturn.

PERIODIC MAINTENANCE AND MINOR REPAIR

Periodic inspection, adjustment, and lubrication will keep your motorcycle in the safest and most efficient condition possible. Safety is an obligation of the motorcycle owner. The maintenance and lubrication schedule chart should be considered strictly as a guide to general maintenance and lubrication intervals. YOU MUST TAKE INTO CONSIDERATION THAT WEATHER, TERRAIN, GEOGRAPHICAL LOCATIONS, AND A VARIETY OF INDIVIDUAL USES ALL TEND TO DEMAND THAT EACH OWNER ALTER THIS TIME SCHEDULE TO SHORTER INTERVALS TO MATCH HIS ENVIRONMENT. The most important points of motorcycle inspection, adjustment, and lubrication are explained in the following pages.

WARNING: _____

If you are not familiar with motorcycle service, this work should be done by a Yamaha dealer.

Tool kit

The service information included in this manual is intended to provide you, the owner, with the necessary information for completing some of your own preventive maintenance and minor repairs. The tools provided in the owner's tool kit are sufficient for most of these purposes; however a torque wrench is also necessary to properly tighten nuts and bolts.

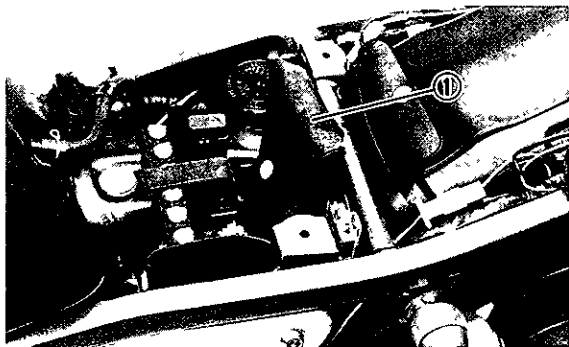

1 Tool kit

U-060

NOTE:

If you do not have a torque wrench available during a service operation requiring one, take your motorcycle to a Yamaha dealer to check the torque settings and adjust them as necessary

U-671

WARNING:

Modifications to this motorcycle not approved by Yamaha may cause loss of performance, and render it unsafe for use. Consult a Yamaha dealer before attempting any changes.

PERIODIC MAINTENANCE/LUBRICATION

Unit km (miles)

ITEM	REMARKS	BREAK-IN 1,000(600)	EVERY	
			6,000 (4,000) or 6 months	12,000 (8,000) or 12 months
Valve(s)*	Check valve clearance Adjust if necessary	○	○	○
Spark plug	Check condition Clean or replace if necessary	○	○	○
Air filter	Clean Replace if necessary		○	○
Carburetor*	Check idle speed(/synchronization)/starter operation Adjust if necessary	○	○	○
Fuel line*	Check fuel hose (and vacuum pipe) for cracks or damage Replace if necessary		○	○
Engine oil	Replace (Warm engine before draining)	○	○	○
Engine oil filter*	Replace	○		○
Brake*	Check operation/fluid leakage/See NOTE Correct if necessary		○	○
Clutch	Check operation Adjust if necessary		○	○
Rear arm pivot*	Check rear arm assembly for looseness Correct if necessary Moderately repack **	○	○	○
Wheels*	Check balance/damage/runout Repair if necessary		○	○
Wheel bearings*	Check bearings assembly for looseness/damage Replace if damaged		○	○
Steering bearing*	Check bearings assembly for looseness Correct if necessary Moderately repack every 24,000 (16,000) or 24 months **	○		○

ITEM	REMARKS	BREAK-IN 1,000(600)	EVERY	
			6,000 (4,000) or 6 months	12,000 (8,000) or 12 months
Front forks*	Check operation/oil leakage Repair if necessary		○	○
Rear shock absorber*	Check operation/oil leakage Repair if necessary		○	○
Drive chain	Check chain slack/alignment Adjust if necessary Clean and lube		EVERY 500 (300)	
Fittings/Fasteners*	Check all chassis fittings and fasteners Correct if necessary	○	○	○
Sidestand*	Check operation Repair if necessary	○	○	○
Battery*	Check specific gravity Check breather pipe for proper operation Correct if necessary		○	○

* It is recommended that these items be serviced by a Yamaha dealer

** Medium weight wheel bearing grease

NOTE:

Brake fluid replacement

- 1 When disassembling the master cylinder or caliper cylinder, replace the brake fluid. Normally check the brake fluid level and add the fluid as required
 - 2 On the inner parts of the master cylinder and caliper cylinder, replace the oil seals every two years.
 - 3 Replace the brake hoses every four years, or if cracked or damaged
-

Torque specifications

Use a torque wrench to tighten these items. It is recommended that these items be checked occasionally, especially before a long trip.

Always check the tightness of these items whenever they are loosened for any reason.

Item	Torque		
	Nm	m·kg	ft·lb
Spark plug	18	1 8	13
Engine drain plug (crankcase)	30	3 0	22
Engine drain plug (oil tank)	30	3 0	22
Oil filter bolt	10	1 0	7 2
Front fork cap bolt	23	2 3	17
Front fork pinch bolt	9	0 9	6 5
Front axle pinch bolt	20	2 0	14
Front axle	105	10 5	75
Rear wheel axle	105	10 5	75
Rear wheel axle lock nut	60	6 0	43

A (Nut)	B (Bolt)	General torque specifications		
		Nm	m·kg	ft·lb
10 mm	6 mm	6	0 6	4 3
12 mm	8 mm	15	1 5	11
14 mm	10 mm	30	3 0	22
17 mm	12 mm	55	5 5	40
19 mm	14 mm	85	8 5	61
22 mm	16 mm	130	13 0	94

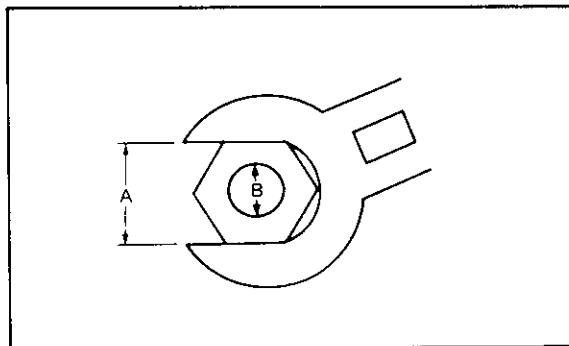

Engine oil

In this model, the dry sump lubrication system is used. That is, oil is supplied to the engine by means of the feed pump, after lubricating is over, the oil is fed back to the oil tank by means of the scavenging pump. Therefore, the oil level can be checked at the oil tank

1. Oil level measurement

- Place the motorcycle on a level place and hold it in an upright position
- Remove the oil tank cap, and check the oil level.

NOTE: _____

When checking, do not screw the oil level gauge into the oil tank. Insert the gauge lightly. For accuracy, check with the motorcycle held upright.

- If the oil level is between the minimum and maximum level lines marked on the oil level gauge, you may start the engine. If there is no oil on the oil level gauge, add oil up to the minimum level.

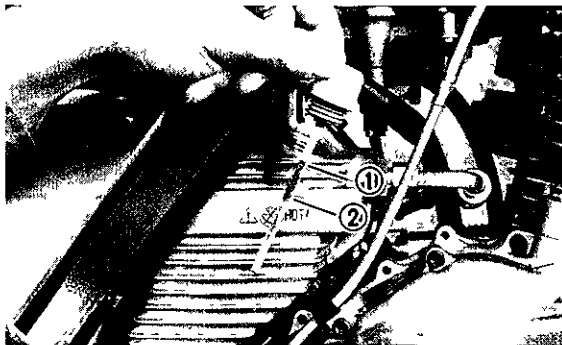

1 Maximum level

2 Minimum level

- Start the engine and warm up until the oil temperature rises to approximately 60°C (140°F).
- Idle the engine more than 10 seconds while keeping the motorcycle upright. Then stop the engine and check the oil level on the upright motorcycle.

- f Adjust the oil level to the maximum level line.

U-300

CAUTION:

Do not run the motorcycle until you know the motorcycle has enough engine oil.

U-715

WARNING:

Never attempt to remove the oil tank cap just after high speed operation. The heated oil could spout out, causing danger. Wait until the oil cools down to approximately 60°C (140°F).

- c Remove the oil tank cap, drain bolts (at two places), and air bleed screw attached to the oil filter cover

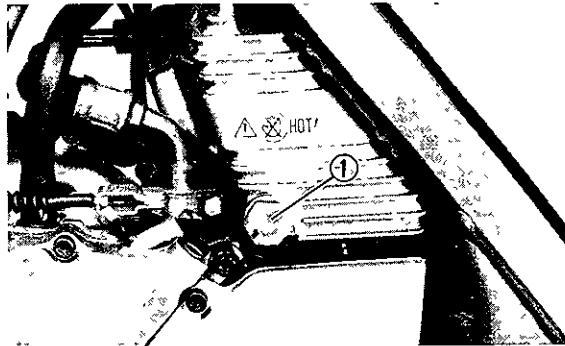

1 Drain bolt

- 2 Engine oil replacement
 - a Start the engine and stop after a few minutes of warm-up
 - b Place an oil receiver under the engine

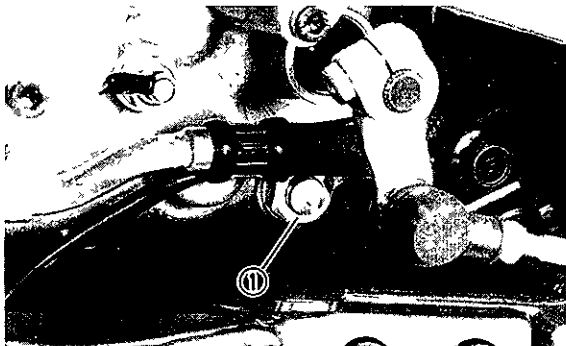

1 Drain bolt

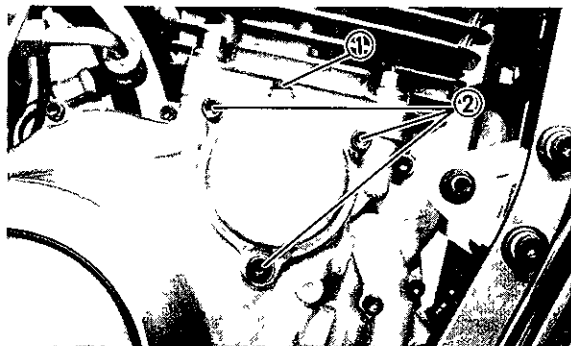

1 Air bleed screw 2 Filter cover screw

U-068

NOTE:

The oil filter cover is secured by three screws. The lower one should be removed so that the filter cavity will drain.

- d. Check each gasket. If damaged, replace.
- e. Remove the other filter cover screws and remove the oil filter cover. Replace the filter element.
- f. Check O-ring for damage. Replace if damaged.

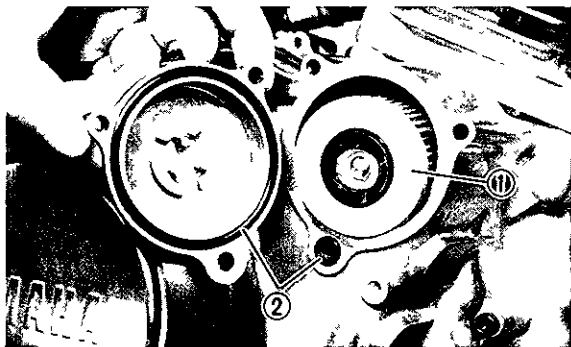

1 Oil filter element 2 Proper O-ring position

- g. Remove the oil hose and oil strainer.
- h. Clean the oil strainer with solvent
- i. Check the oil strainer and O-rings for damage.
- j. Install the drain bolts (at two places), the air bleed screw, and the filter cover screw.

Tightening torque:

Drain bolt (crankcase)

30 Nm (3,0 m·kg, 22 ft·lb)

Drain bolt (oil tank)

30 Nm (3,0 m·kg, 22 ft·lb)

Filter cover screw.

10 Nm (1,0 m·kg, 7,2 ft·lb)

Air bleed screw.

5 Nm (0,5 m·kg, 3,6 ft·lb)

- k. Add engine oil. Install the oil tank filler cap and tighten.

Oil capacity. See page 4-4

Recommended oil: See page 4-4

- l. Start the engine and allow a few minutes of warm-up. While warming up, check for oil leakage. If oil leaks, stop the engine immediately, and check for the cause.

- m. Stop the engine and check the oil level.

U-377

CAUTION:

After replacing the engine oil, be sure to check the oil pressure as described below.

1. Remove the air bleed screw from oil filter cover.
2. Start the engine and keep it idling until oil flows out of the bleed hole. If no oil comes out after a lapse of one minute, turn off the engine immediately so it will not seize. In

such a case go to the nearest Yamaha dealer for repairs.

3. After checking, tighten the air bleed screw securely.
-

H-607

Fuel cock cleaning

1. Turn the cock lever to the "ON" or "RES".
2. Remove the drain screw and clean it with solvent. If gasket is damaged, replace.

H-626K

Air filter

- 1 Remove the right side cover.

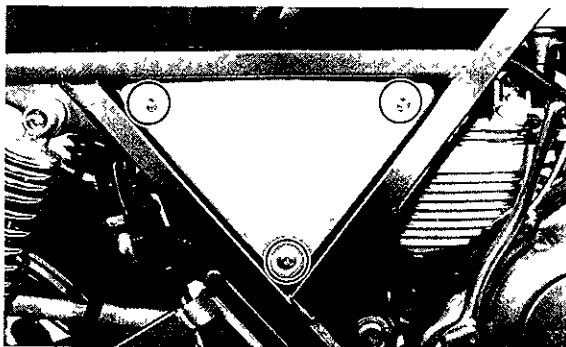

2. Remove the air filter case fitting screws and the filter case cover.

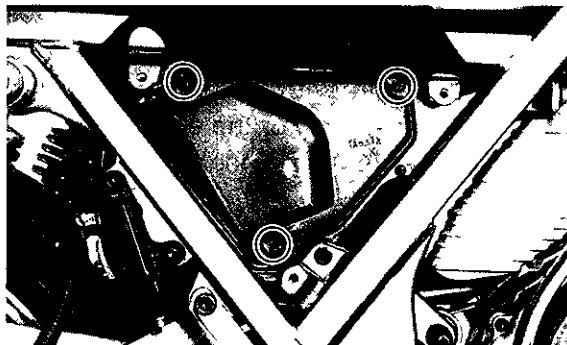

3. Pull out the element

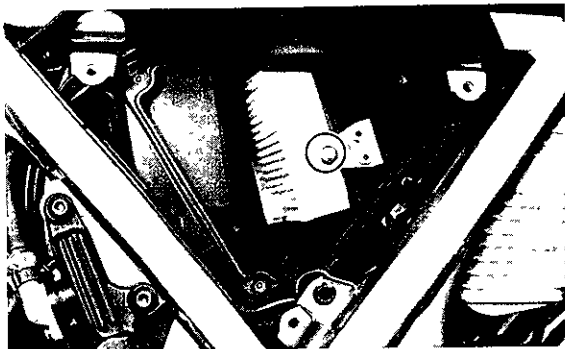

- 4 Tap the element lightly to remove most of the dust and dirt, blow out the remaining dirt with compressed air from the inner surface of the element
If the element is damaged, replace it

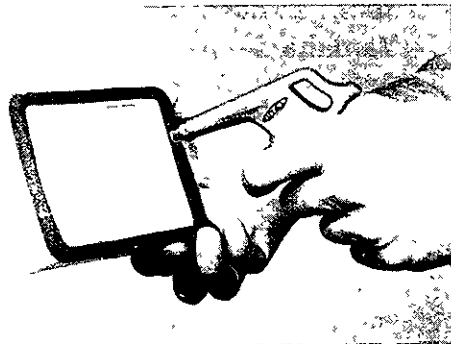

5. Resemble by reversing the removal procedure

U-357

CAUTION:

Make sure the element edge fits into the corresponding filter case groove.

- 6 The air filter element should be cleaned at the specified intervals

CAUTION:

The engine should never be run without the air cleaner element; excessive piston and/or cylinder wear may result.

Carburetor adjustment

The carburetor is a vital part of the engine and requires very sophisticated adjustment. Most adjustments should be left to a Yamaha dealer who has the professional knowledge and experience to do so. However, the following point may be serviced by the owner as part of this routine maintenance

CAUTION:

The carburetor was set at the Yamaha factory after many tests. If the settings are disturbed, poor engine performance and damage may result.

Idle speed adjustment

- 1 Start the engine and warm it up for a few minutes (normally, 1 or 2 minutes) at approximately 1,000 to 2,000 r/min. Occasionally rev the engine to 4,000 to 5,000 r/min. The engine is warm when it quickly responds to the throttle.
2. Set the idle to the specified engine speed by adjusting the throttle stop screw; turn the screw in to increase engine speed, turn the screw out to decrease engine speed.

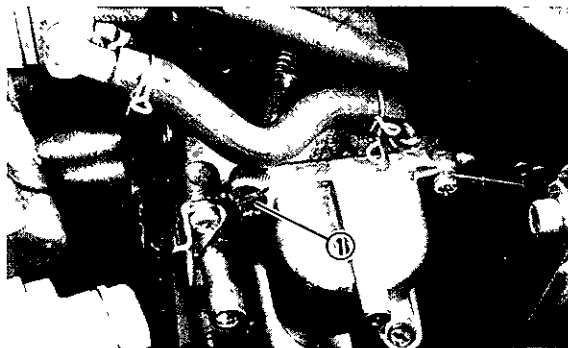

1 Throttle stop screw

Standard idle speed
1,150 ~ 1,250 r/min

U-045

NOTE:

If the specified idle speed cannot be obtained by performing the above adjustment, consult a Yamaha dealer

H-909

Throttle cable adjustment

U-064

NOTE:

Before adjusting the throttle cable free play, the engine idling speed should be adjusted

The throttle cable should have a specified free play in the turning direction at the grip flange. If the play is incorrect, take the following steps for adjustment

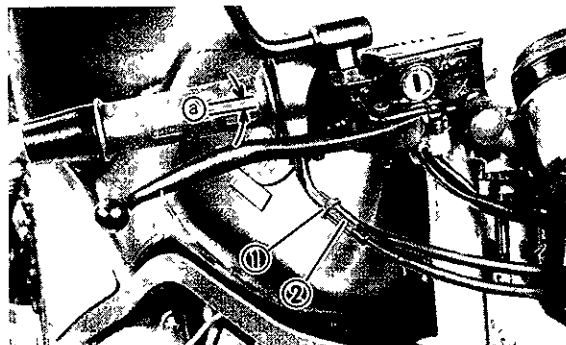

1 Lock nut 2 Adjuster a 2 ~ 5 mm (0.08 ~ 0.20 in)

Free play

2 ~ 5 mm (0.08 ~ 0.20 in)

- 1 Loosen the lock nuts on the carburetor side of throttle cable 1, and turn the adjuster in or out so the play is correct. After the adjustment, be sure to tighten the lock nut.

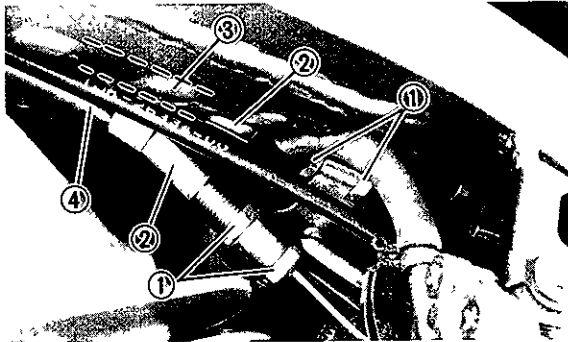

- | | |
|--------------------|--------------------|
| 1 Lock nut | 2 Adjuster |
| 3 Throttle cable 1 | 4 Throttle cable 2 |

- If the play is still incorrect after the adjuster is loosened 5 mm (0.20 in), make an adjustment with the adjuster on the throttle cable 2.

H-908

Valve clearance adjustment

The valve clearance becomes larger with use, resulting in improper fuel/air supply and engine noise. To prevent this, the valve clearance must be adjusted regularly. This adjustment, however, should be left to a professional Yamaha service technician

H-907

Decompression cable adjustment

The decompression cable becomes longer with use, resulting in improper decompression function. To prevent this, the decompression cable must be adjusted regularly. This adjustment, however, should be left to a Yamaha dealer.

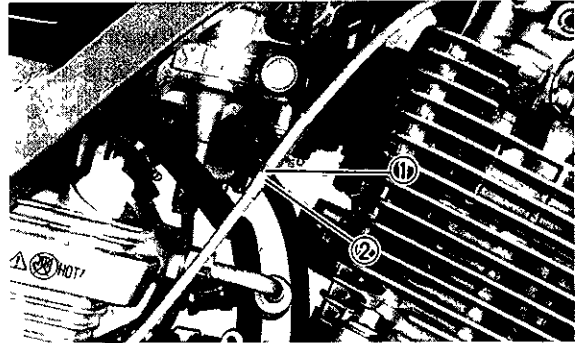

- | | |
|------------|------------|
| 1 Lock nut | 2 Adjuster |
|------------|------------|

Spark plug inspection

The spark plug is an important engine component and is easy to inspect. The condition of the spark plug can indicate something of the condition of the engine. The ideal color on the white porcelain insulator around the center electrode is a medium to light tan color for a motorcycle that is being ridden normally. Do not attempt to diagnose any problems yourself. Instead, take the motorcycle to a Yamaha dealer. You should periodically remove and inspect the spark plug because heat and deposits will cause the spark plug to slowly break down and erode. If electrode erosion becomes excessive, or if carbon and other deposits are excessive, you should replace the spark plug with a proper type plug.

Standard spark plug:

DP8EA-9 (NGK)

(Except for Spain and S. Africa)

DPR8EA-9 (NGK)

(For Spain and S. Africa)

Before installing the spark plug, measure the electrode gap with a wire thickness gauge, adjust the gap to specification as necessary.

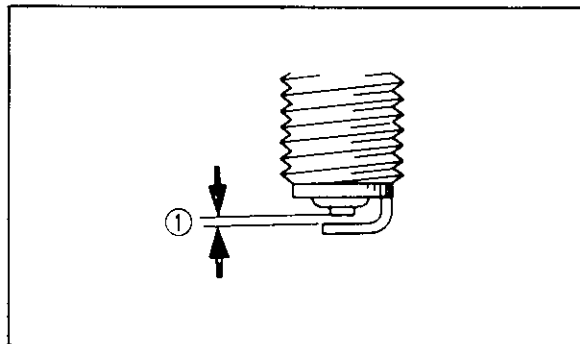

1 Spark plug gap

Spark plug gap.

0.8 ~ 0.9 mm (0.031 ~ 0.035 in)

When installing the plug, always clean the gasket surface and use a new gasket. Wipe off any grime from the threads, and torque the spark plug properly.

Spark plug torque:

18 Nm (1.8 m·kg, 13 ft·lb)

U-038

NOTE:

If a torque wrench is not available when you are installing a spark plug, a good estimate of the correct torque is 1/4 to 1/2 turns past finger tight. Have the spark plug torqued to the correct value as soon as possible with a torque wrench.

H-801

Front brake adjustment

The free play at the end of the front brake lever should be 2 ~ 5 mm (0.08 ~ 0.20 in).

1. Loosen the lock nut.
2. Turn the adjuster so that the brake lever movement at the lever end is 2 ~ 5 mm (0.08 ~ 0.20 in) before the adjuster contacts the master cylinder piston.
3. After adjusting, tighten the lock nut.

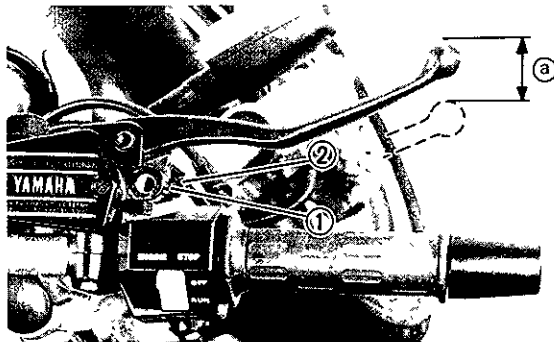

1 Lock nut 2 Adjuster a 2 ~ 5 mm (0.08 ~ 0.20 in)

U-636

WARNING:

Check the brake lever free play. Be sure the brake is working properly.

U-641

WARNING:

A soft or spongy feeling in the brake lever can indicate the presence of air in the brake system. This air must be removed by bleeding the brake system before the motorcycle is operated. Air in the system will cause greatly diminished braking capability and can result in loss of control and an accident. Have a Yamaha dealer inspect and bleed the system if necessary.

H-804

Rear brake adjustment

The brake pedal top end should be 50 mm (2.0 in) below the top of the footrest. If not, ask a Yamaha dealer

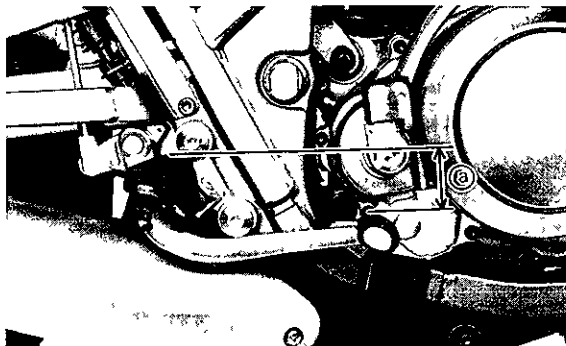

1 50 mm (2.0 in)

U-688

WARNING:

An incorrect free play indicates a hazardous condition in the brake system. Do not operate the motorcycle until the failure in the brake system is corrected. Ask a Yamaha dealer for immediate repairs.

H-833

Brake light switch adjustment

The brake light switch is operated by movement of the brake pedal. To adjust, hold the main body of the switch with your hand so it does not rotate and turn the adjusting nut. Proper adjustment is achieved when the brake light comes on just before the brake begins to take effect.

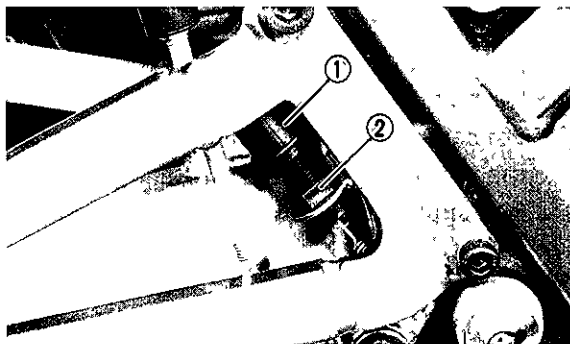

1 Main body

2 Adjusting nut

H-836

Checking the front and rear brake pads

A wear indicator is attached to each brake pad to facilitate disc brake pad checks. This indicator permits a visual check without disassembling the pads. To check, depress the brake and inspect the wear indicator. If the wear indicator is ALMOST in contact with the disc plate, ask a Yamaha dealer to replace the pads.

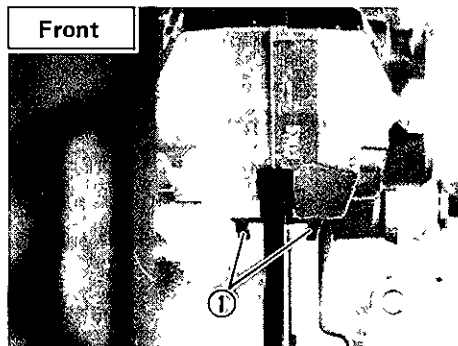

1 Wear indicator

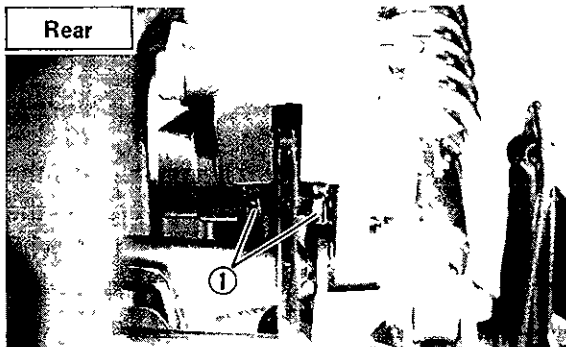

1 Wear indicator

H-828

Inspecting the brake fluid level

Insufficient brake fluid may let air enter the brake system, possibly causing the brakes to become ineffective. Before riding, check the brake fluid level and replenish when necessary, observe these precautions

- 1 When checking the fluid level, make sure the master cylinder top is horizontal by turning the handlebars.

- 2 Use only the designated quality brake fluid: otherwise, the rubber seals may deteriorate, causing leakage and poor brake performance

Recommended brake fluids DOT #3

- 3 Refill with the same type of brake fluid, mixing fluids may result in a harmful chemical reaction and lead to poor performance.
- 4 Be careful that water does not enter the master cylinder when refilling. Water will significantly lower the boiling point of the fluid and may result in vapor lock.
- 5 Brake fluid may erode painted surfaces or plastic parts. Always clean up spilled fluid immediately.
- 6 Have a Yamaha dealer check the cause if the brake fluid level goes down

Brake fluid replacement

1. Complete fluid replacement should be done only by trained Yamaha service personnel.
2. Have a Yamaha dealer replace the following components when indicated in the schedule or when they are damaged or leaking
 - a. Replace all rubber seals every two years.
 - b. Replace all hoses every four years.

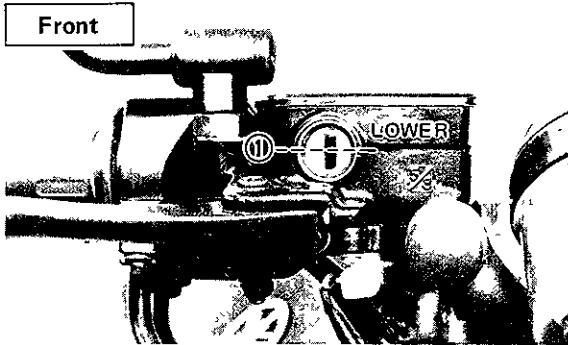

1 Lower level



1 Lower level

I-001

Clutch adjustment

This model has two clutch cable length adjusters. The cable length adjusters are used to take up slack from cable stretch and to provide sufficient free play for proper clutch operation.

Normally, once the clutch cable length adjuster (crankcase) is properly set; the only adjustment required is maintenance of free play at the clutch cable length adjuster (handlebar lever).

Free play adjustment

The clutch should be adjusted to suit the rider's preference, but, free play at the lever pivot should be 2 ~ 3 mm (0.08 ~ 0.12 in). Loosen either the handlebar lever adjuster lock nut or the cable length adjuster lock nut. Turn the cable length adjuster either in or out until proper lever free play is achieved.

Clutch lever free play:
2 ~ 3 mm (0.08 ~ 0.12 in)

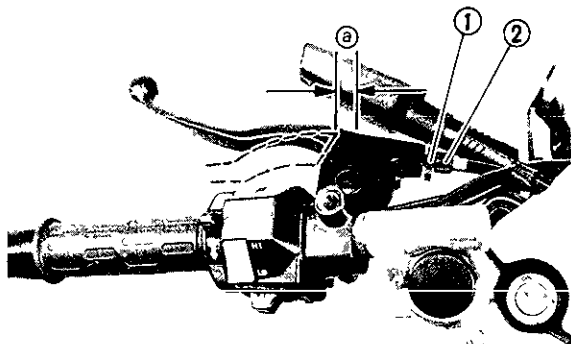

1 Lock nut 2 Adjuster a 2 ~ 3 mm (0.08 ~ 0.12 in)

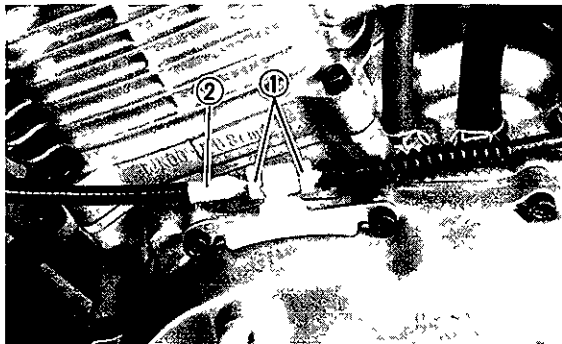

1 Lock nut 2 Adjuster

I-408

Drive chain slack check

U-048

NOTE: _____
Before checking and/or adjusting the chain slack, rotate the rear wheel through several revolutions. Check the chain slack several times to find the point where the chain is the tightest. Check and/or adjust the chain slack where the rear wheel is in this "tight chain" position.

To check the chain slack the motorcycle must stand vertically with its both wheels on the ground and without a rider. Check the slack at the position shown in the illustration. The normal vertical deflection is approximately 15 ~ 20 mm (0.6 ~ 0.8 in). If the deflection exceeds 20 mm (0.8 in) adjust the chain slack.

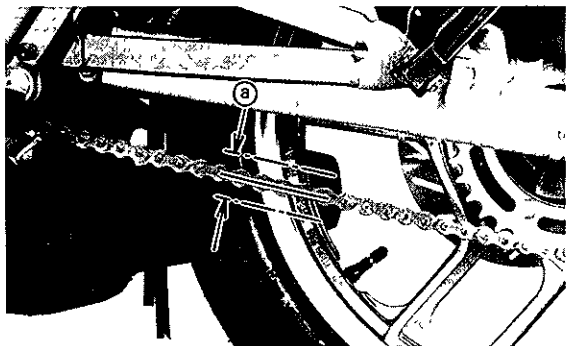

a 15 ~ 20 mm (0.6 ~ 0.8 in)

I-410

Drive chain slack adjustment

1. Loosen the rear wheel axle lock nut and axle nut.
2. Loosen the lock nuts on each side. To tighten the chain, turn chain adjuster clockwise. To loosen the chain, turn the adjuster counterclockwise and push the wheel forward. Turn each adjuster exactly the same amount to maintain correct axle alignment. (There are marks on each side of swingarm and on each chain adjuster; use them to check for proper alignment.)

U-333

CAUTION:

Too small chain slack will overload the engine and other vital parts; keep the slack within the specified limits.

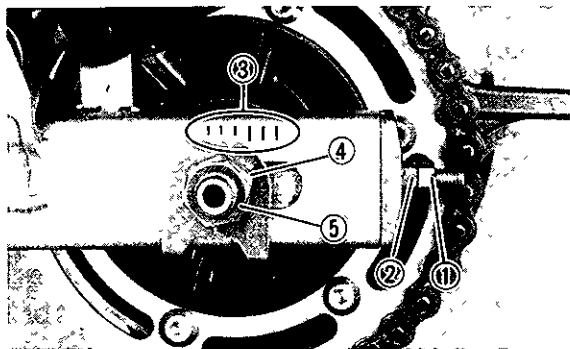

- | | |
|------------------------|------------|
| 1 Lock nut | 2 Adjuster |
| 3. Marks for alignment | 4 Axle nut |
| 5 Axle lock nut | |

- 3 After adjusting, be sure to tighten the lock nuts
4. Make sure the axle nut and axle lock nut are properly torqued

Tightning torque

Axle nut

105 Nm (10.5 m·kg, 75 ft·lb)

Axle lock nut

60 Nm (6.0 m·kg, 43 ft·lb)

Drive chain lubrication

The chain consists of many parts which work against each other. If the chain is not maintained properly, it will wear out rapidly, therefore, form the habit of periodically servicing the chain. This service is especially necessary when riding in dusty conditions. This motorcycle has a drive chain with small rubber O-rings between the chain plates. Steam cleaning, high-pressure washes, and certain solvent can damage these O-rings. Use only kerosene to clean the drive chain. Wipe it dry, and thoroughly lubricate it with SAE 30 ~ 50W motor oil. Do not use any other lubricants on the drive chain. They may contain solvents that could damage the O-rings.

I-107

Cable inspection and lubrication

U-646

WARNING:

Damage to the outer housing of the various cables may cause corrosion and interfere with the movement of the cable. An unsafe condition may result so replace such cables as soon as possible.

Lubricate the inner cable and the cable end. If they do not operate smoothly, ask a Yamaha dealer to replace them.

Recommended lubricant.
SAE 10W30 motor oil

I-102

Throttle cable and grip lubrication

The throttle twist grip assembly should be greased at the time that the cable is lubricated, since the grip must be removed to get at the end of the throttle cable. Two screws clamp the throttle housing to the handlebar. Once these two are removed, the end of the cable can be held high to pour in several drops of lubricant. With the throttle grip disassembled, coat the metal surface of the grip assembly with a suitable all-purpose grease

I-306

Brake and change pedals

Lubricate the pivoting parts

Recommended lubricant.
SAE 10W30 motor oil

I-307

Brake and clutch levers

Lubricate the pivoting parts

Recommended lubricant
SAE 10W30 motor oil

I-311

Sidestand

Lubricate the pivoting parts. Check to see that the sidestand move up and down smoothly.

Recommended lubricant.
SAE 10W30 motor oil

U-704

WARNING:

If the sidestand movement is not smooth, consult a Yamaha dealer.

I-314

Rear suspension

Lubricate the pivoting parts

Recommended lubricant
Swingarm pivots Bearing grease
Other pivots. Lithium soap base grease

I-524

Front fork oil change

U-649

WARNING:

1. Fork oil leakage can cause loss of stability and safe handling. Have any problem corrected before operating the motorcycle.
 2. Securely support the motorcycle so there is no danger of it falling over.
-
1. Elevate the front wheel by placing a suitable stand under the engine.
 2. Remove the cap from the top of each fork.

3. Loosen the front fork pinch bolts and remove the cap bolts from the inner fork tubes.

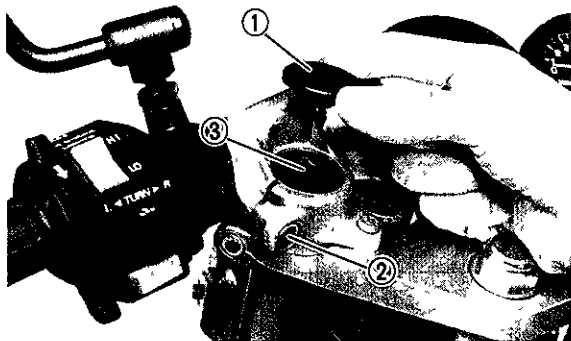

1 Cap 2 Pinch bolt 3 Cap bolt

- 4 Place an open container under each drain hole. Remove the drain screw from each outer tube.

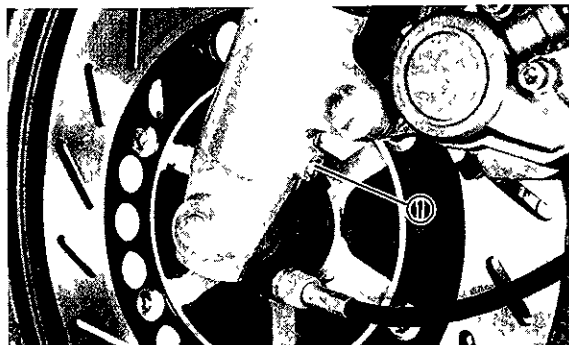

1 Drain screw

U-650

WARNING:

Do not let oil contact the disc brake components. If any oil should contact the brake components, it must be removed before the motorcycle is operated. Oil will cause diminished braking capacity and will damage the rubber components of the brake assembly.

- 5 After most of the oil has been drained, slowly pump the forks up and down to remove any remaining oil
- 6 Inspect the drain screw gasket. Replace if damaged Reinstall the drain screws.
7. Pour the specified amount of oil into each fork inner tube

Front fork oil capacity (each fork)
321 Nm (11.3 Imp oz, 10.9 US oz)
Recommended oil
Fork oil 10W or Equivalent

- 8 After filling, slowly pump the forks up and down to distribute the oil
- 9 Inspect the O-ring on the cap bolt. Replace if damaged
- 10 Reinstall the cap bolt, cap, and tighten the pinch bolt

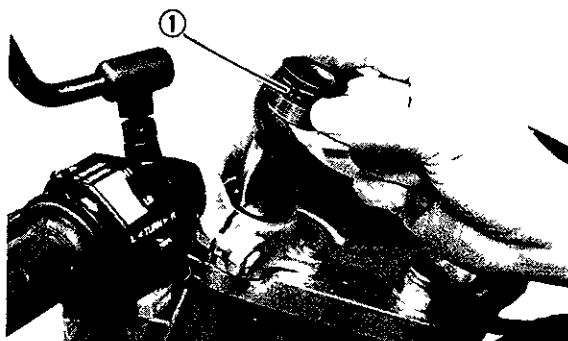

1 O-ring

Tightening torque.

Cap bolt.

23 Nm (2.3 m·kg, 17 ft·lb)

Pinch bolt.

9 Nm (0.9 m·kg, 6.5 ft·lb)

I-509

Rear shock absorber adjustment

Spring preload

If the spring seat is raised, the spring becomes stiffer, and if lowered, it becomes softer

Standard position: B

A — Softest

E — Stiffest

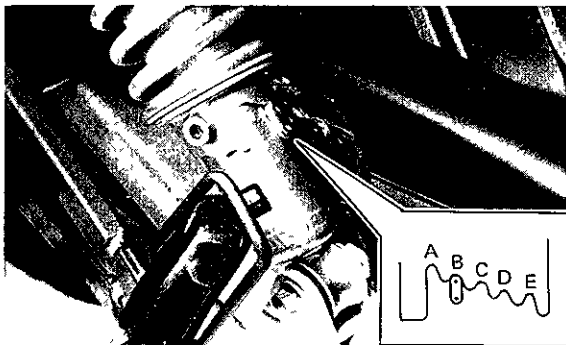

U-652

WARNING:

Always adjust each shock absorber to the same setting. Uneven adjustment can cause poor handling and loss of stability.

I-603

Steering inspection

Periodically inspect the condition of the steering. Worn out or loose steering bearings may be dangerous.

Place a block under the engine to raise the front wheel off the ground.

Hold the lower end of the front forks and try to move them forward and backward. If any free play can be felt, ask a Yamaha dealer to inspect and adjust the steering. Inspection is easier if the front wheel is removed.

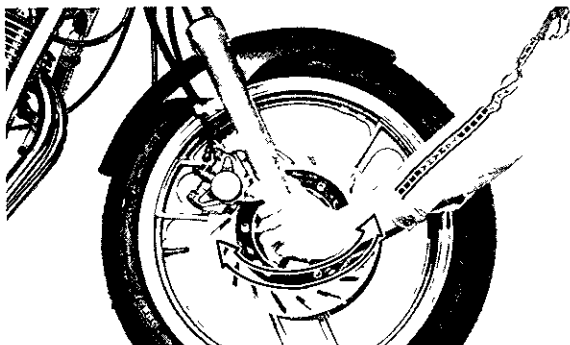

U-657

WARNING:

Securely support the motorcycle so there is no danger of it falling over.

I-602

Wheel bearings

If the wheel bearings in the front or rear wheel allow play in the wheel hub or if the wheel does not turn smoothly, have a Yamaha dealer inspect the wheel bearings. The wheel bearings should be inspected according to the Maintenance Schedule.

I-700

Battery

Check the level of the battery electrolyte and see that the terminals are tight. Add distilled water if the electrolyte level is low

U-336

CAUTION:

When inspecting the battery, be sure the breather pipe is routed correctly. If the breather pipe touches the frame or exits in such a way as to cause battery electrolyte or gas to exit onto the frame, structural and cosmetic damage to the motorcycle can occur.

WARNING:

Battery electrolyte is poisonous and dangerous, causing severe burns, etc. It contains sulfuric acid. Avoid contact with skin, eyes or clothing.

Antidote: **EXTERNAL**-Flush with water. **INTERNAL**-Drink large quantities of water or milk. Follow with milk of magnesia, beaten egg, or vegetable oil. Call a physician immediately.

Eyes: Flush with water for 15 minutes and get prompt medical attention. Batteries produce explosive gases. Keep sparks, flame, cigarettes etc., away. Ventilate when charging or using in an enclosed space. Always shield your eyes when working near batteries. **KEEP OUT OF REACH OF CHILDREN.**

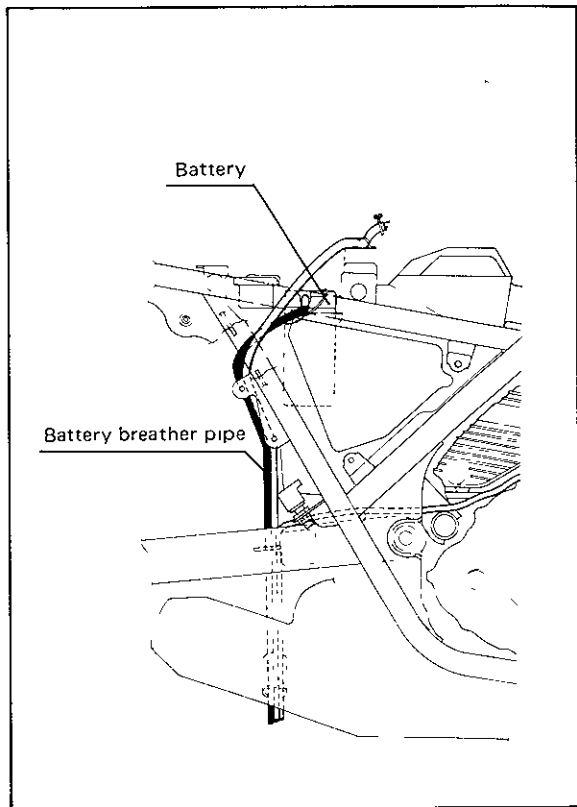

Replenishing the battery fluid

A poorly maintained battery will deteriorate quickly. The battery fluid should be checked at least once a month.

1. The level should be between the upper and lower level marks. Use only distilled water if refilling is necessary.

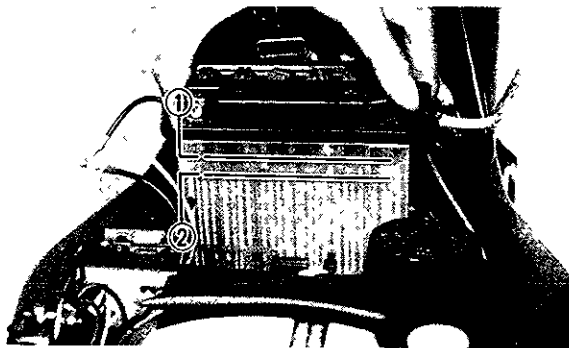

1 Upper level

1 Lower level

CAUTION:

Normal tap water contains minerals which are harmful to a battery; therefore, refill only with distilled water.

WARNING:

Battery fluid on the chain can cause premature failure and possibly an accident.

2. When the motorcycle will not be used for a month or longer, remove the battery and store it in a cool, dark place. Completely recharge the battery before reusing.
3. If the battery will be stored for a longer period than the above, check the specific gravity of the fluid at least once a month and recharge the battery when it is too low.

4. Always make sure the connections are correct when putting the battery back in the motorcycle.

Make sure the breather pipe is properly connected and is not damaged or obstructed.

I-907

Circuit breaker

This model is equipped with a circuit breaker. If any problem should occur to an electric component and cause a short circuit, this breaker works to shut off the current. If the current is thus shut off by the breaker, perform the following procedure:

1. Turn off the ignition switch and the switch in the circuit in question
2. Push in the breaker knob.

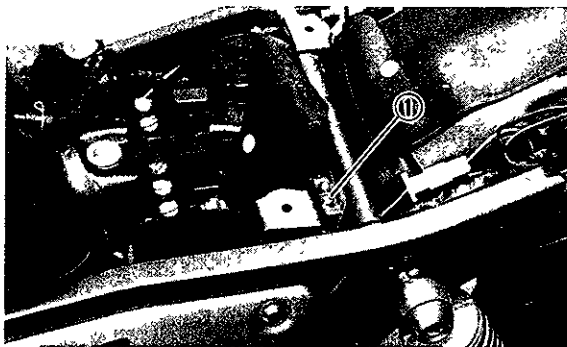

1 Circuit breaker

U-365

CAUTION:

Wait 30 seconds before resetting the circuit breaker.

3. Turn on the switches and see if the electrical device operates. If the circuit breaker interrupts the circuit again, consult a Yamaha dealer.

Replacing the headlight bulb

This motorcycle is equipped with a quartz bulb headlight. If the headlight bulb burns out, replace the bulb as follows:

- 1 Remove the 2 screws holding the light unit assembly

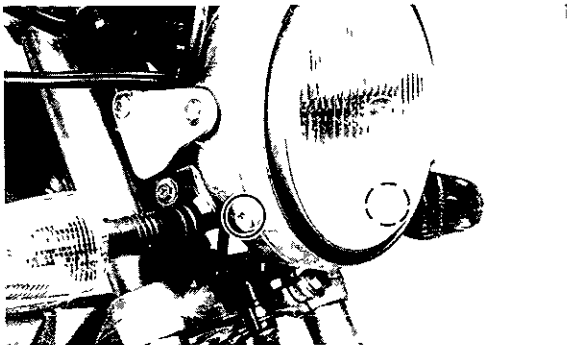

2. Disconnect the lead wires, and remove the light unit assembly.

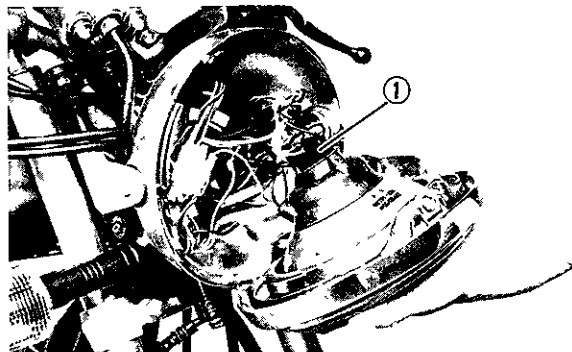

Headlight lead

3. Turn the bulb holder counterclockwise and remove the defective bulb.

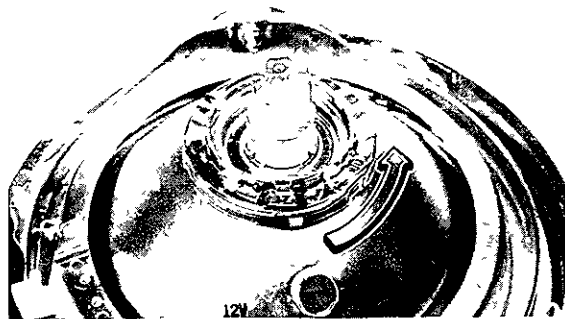

WARNING:

Keep flammable products or your hands away from the bulb while it is on, it will be hot. Do not touch the bulb until it cools down.

4. Slip a new bulb into position and secure it in place with the bulb holder.

CAUTION:

Avoid touching the glass part of the bulb. Keep it free from oil; otherwise, the transparency of the glass, life of the bulb, and illuminous flux will be adversely affected. If oil gets on the bulb, thoroughly clean it with a cloth moistened with alcohol or lacquer thinner.

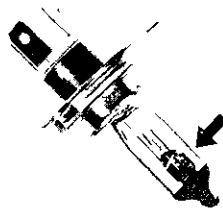

- 5 Reinstall the light unit assembly. Adjust the headlight beam if necessary.

Headlight beam adjustment

CAUTION:

For the headlight beam adjustment, be sure to proceed as follows; (It is advisable to have a Yamaha dealer make this adjustment.)

1 Horizontal adjustment:

To adjust the beam to the right, turn the adjusting screw clockwise.

To adjust the beam to the left, turn the screw counterclockwise.

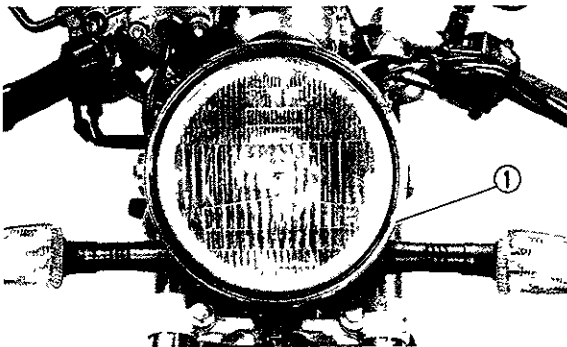

1 Horizontal adjusting screw

2 Vertical adjustment.

- a Loosen the vertical adjusting screw.
- b. Adjust vertically by moving the headlight body. When proper adjustment is achieved, retighten the adjusting screw.

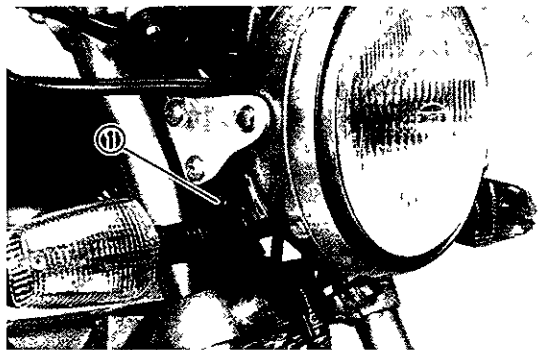

1 Vertical adjusting screw

J-218K

Front wheel removal

- 1 Elevate the front wheel by placing a suitable stand under the engine.
- 2 Remove the speedometer cable at the speedometer gear housing

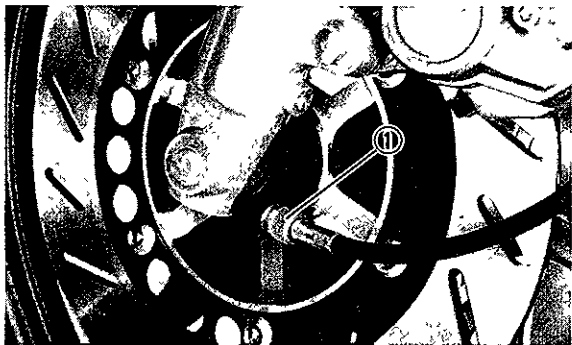

1. Speedometer cable

3. Remove the front fork brace securing bolts and remove the brace with fender.

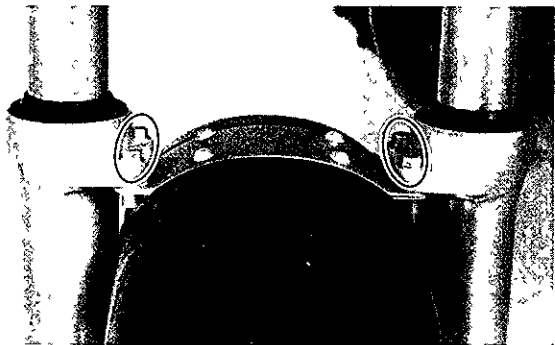

4. Loosen the pinch bolt.

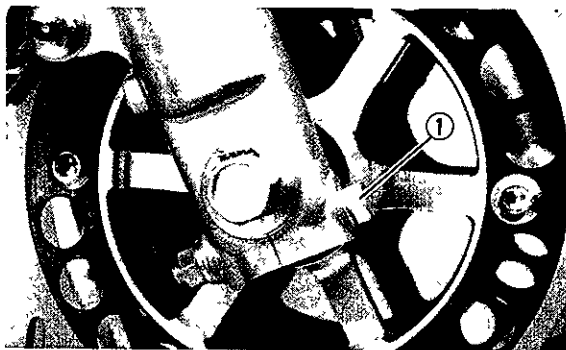

1 Pinch bolt

5. Remove the axle. Make sure the motorcycle is properly supported.

U-054

NOTE: _____

Do not depress the brake lever when the disc is off the caliper as the brake pads will be forced shut.

- 6 Lower the wheel until the discs come off the calipers. Turn the calipers outward so they do not obstruct the wheel and remove the wheel.

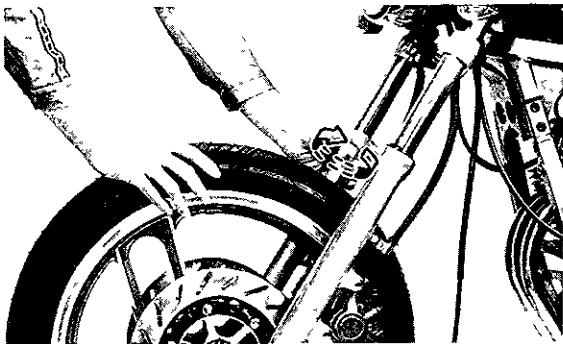

J-217

Front wheel installation

When installing the front wheel, reverse the removal procedure

Pay attention to the following points

1. Make sure the wheel hub and the speedometer clutch assembly are installed with the projections meshed into the slots.

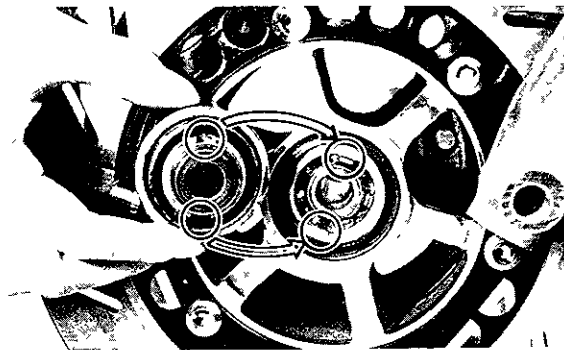

- 2 Make sure the projecting portion (torque stopper) of the speedometer housing is positioned correctly.

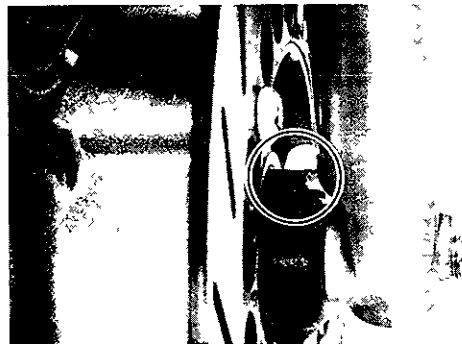

3. Make sure the axle is properly torqued.

Tightening torque
105 Nm (10.5 m·kg, 75 ft·lb)

4. Before tightening the pinch bolt, compress the front forks several times to check for proper fork operation.
5. Tighten the axle pinch bolt

Axle pinch bolt torque.
20 Nm (2.0 m·kg, 14 ft·lb)

J-329

Rear wheel removal

U-662

WARNING:

It is advisable to have a Yamaha dealer service the rear wheel.

1. Elevate the rear wheel by placing a suitable stand.
2. Remove the axle lock nut and axle nut.

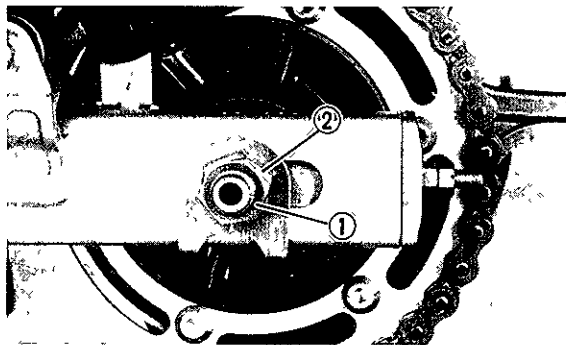

1 Axle lock nut 2 Axle nut

3. Remove the caliper installation bolt from the tension bar by removing the cotter pin and nut.

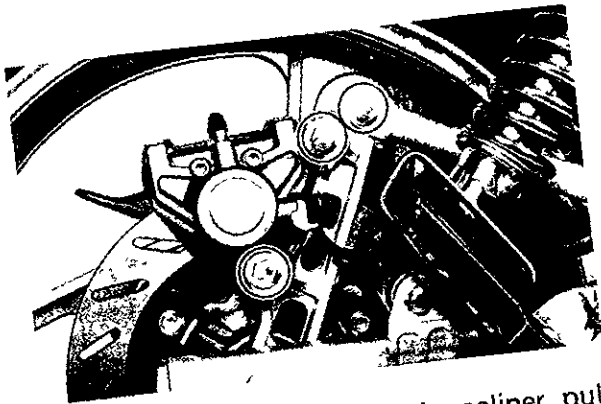

4. While supporting the brake caliper, pull out the rear axle.
5. Push the wheel forward and remove the drive chain

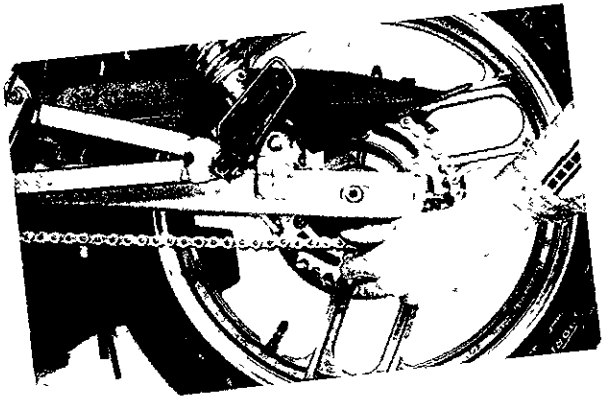

6. Remove the wheel assembly.

U-055

NOTE: _____
Do not depress the brake pedal when the disc is off the caliper as the brake pads will be forced shut

U-056

NOTE: _____
You do not have to disassemble the chain in order to remove or install the rear wheel.

Rear wheel installation

When installing the rear wheel, reverse the removal procedure. Pay attention to the following points.

1. Make sure there is enough gap between the brake pads before inserting the brake disc.
2. Adjust the drive chain.
3. Make sure the axle nut, axle lock nut and tension bar bolt are properly torqued.

WARNING:

Always use a new cotter pin on the tension bar bolt.

Tightening torque

Axle nut.

105 Nm (10.5 m·kg, 75 ft·lb)

Axle lock nut:

60 Nm (6.0 m·kg, 43 ft·lb)

Tension bar bolt.

25 Nm (2.5 m·kg, 18 ft·lb)

Troubleshooting

Although Yamaha motorcycles receive a rigid inspection before shipment from the factory, trouble may occur during operation. Any problem in the fuel, compression, or ignition systems can cause poor starting and a loss of power. The troubleshooting chart describes a quick, easy procedure for checking these systems.

If your motorcycle requires any repair, bring it to a Yamaha dealer. The skilled technicians at a Yamaha dealer have the tools, experience, and know-how to properly service your motorcycle. Use only genuine Yamaha parts on your motorcycle. Imitation parts may look like Yamaha parts, but they are often inferior. Consequently, they have a shorter service life and can lead to expensive repair bills.

Troubleshooting chart

U-663

WARNING:

Never check the fuel system while smoking or in the vicinity of an open flame.

CJ5-08

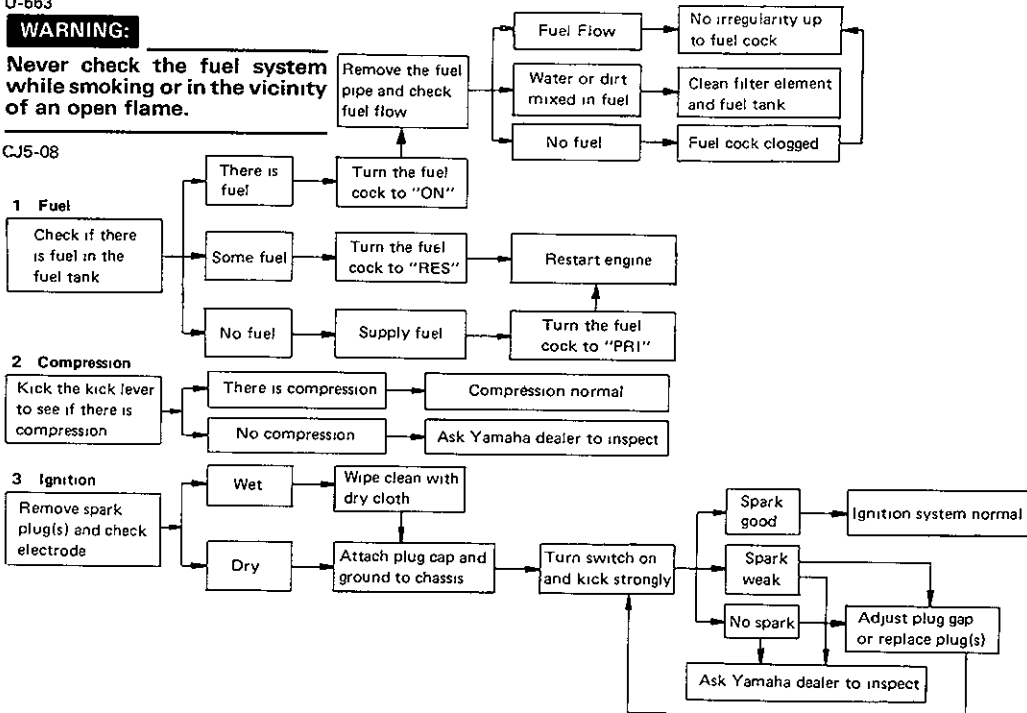

CLEANING AND STORAGE

K-009

A. CLEANING

Frequent thorough cleaning of your motorcycle will not only enhance its appearance but will improve its general performance and extend the useful life of many components

- 1 Before cleaning the motorcycle.
 - a Block off the end of exhaust pipe to prevent water entry, a plastic bag and strong rubber band may be used
 - b Make sure the spark plug(s) and all filler caps are properly installed.
- 2 If the engine case is excessively greasy, apply degreaser with a paint brush. Do not apply degreaser to the chain, sprockets, or wheel axles
- 3 Rinse the dirt and degreaser off with a garden hose, use only enough pressure to do the job

CAUTION:

Excessive hose pressure may cause water seepage and contamination of wheel bearings, front forks, brakes and transmission seals. Many expensive repair bills have resulted from improper high pressure detergent applications such as those available in coin-operated car washers.

4. Once the majority of the dirt has been hosed off, wash all surfaces with warm water and mild, detergent-type soap. An old tooth brush or bottle brush is handy for hard-to-get-to places.
- 5 Rinse the motorcycle off immediately with clean water and dry all surfaces with a chamois, clean towel, or soft absorbent cloth.

6. Dry the chain and lubricate it to prevent rust.
7. Clean the seat with a vinyl upholstery cleaner to keep the cover pliable and glossy.
8. Automotive-type wax may be applied to all painted and chrome-plated surfaces. Avoid combination cleaner-waxes. Many contain abrasives which may mar the paint or protective finish. When finished, start the engine and let it idle for several minutes.

K-010

B. STORAGE

Long term storage (60 days or more) of your motorcycle will require some preventive procedures to guard against deterioration. After thoroughly cleaning the motorcycle, prepare for storage as follows:

1. Drain the fuel tank, fuel lines, and carburetor float bowl(s).

2. Remove empty fuel tank, pour a cup of SAE 10W30 or 20W40 motor oil in tank, shake the tank to coat the inner surfaces thoroughly and drain off the excess oil. Reinstall the tank.
3. Remove the spark plug(s), pour about one tablespoon of SAE 10W30 or 20W40 motor oil in the spark plug hole(s) and reinstall the spark plug. Kick the engine over several times (with ignition off) to coat the cylinder walls with oil.
4. Remove the drive chain. Thoroughly clean the chain with kerosene and lubricate. Reinstall the chain or store it in a plastic bag (tied to frame for safe-keeping).
5. Lubricate all control cables
6. Block up the frame to raise both wheels off the ground.
7. Tie a plastic bag over the exhaust pipe outlet to prevent moisture from entering.

- 8 If storing in a humid or salt-air atmosphere, coat all exposed metal surfaces with a light film of oil. Do not apply oil to any rubber parts or the seat cover.
- 9 Remove the battery and charge it. Store it in a dry place and recharge it once a month. Do not store the battery in an excessively warm or cold place (less than 0° C (30° F) or more than 30° C (90° F)).

U-058

NOTE: _____
Make any necessary repairs before storing the motorcycle

L-006

NOISE REGULATION (For Australia)

This motorcycle was manufactured to comply with ADR 39 for motorcycle and moped noise.

SRX600 (1XR)

Engine speed at maximum power

6,500 rpm

Stationary noise level

87.6 dB(A)

SPECIFICATIONS

Model	SRX600
Dimension	
Overall length	2,125 mm (83.7 in)
Overall width	705 mm (27.8 in)
Overall height	1,055 mm (41.5 in)
Seat height	770 mm (30.3 in)
Wheel base	1,385 mm (54.5 in)
Minimum ground clearance	145 mm (5.7 in)
Basic weight	
With oil and full fuel tank	176 kg (388 lb)
Minimum turning radius:	2,600 mm (102.4 in)
Engine	
Type	Air cooled 4-stroke, gasoline, torque induction, SOHC,
Model	1XR, 1XL (For Spain)
Cylinder arrangement	Single cylinder, Forward inclined
Displacement	608 cm ³
Bore x Stroke	96.0 x 84.0 mm (3.8 x 3.3 in)
Compression ratio	8.5 : 1
Starting system	Kick starter
Lubrication system	Dry sump

Model	SRX600
Tire: Type Size — Front Rear	Tubeless 100/80-18 53S 120/80-18 62S
Brake Front brake type Operation Rear brake type Operation	Dual, Disk brake Right hand operation Single, Disk brake Right foot operation
Suspension Front Rear	Telescopic fork Swing arm
Shock absorber Front Rear	Coil spring, Oil damper Coil spring, Oil damper
Wheel travel Front Rear	140 mm (5.5 in) 100 mm (3.9 in)

Model	SRX600
Electrical Ignition system Generator system Battery type/Capacity	CDI magneto AC generator 12N5-3B/12V 5AH
Headlight type.	Quarz bulb
Bulb wattage/Quantity Headlight Tail/Brake light Flasher light Auxiliary light Meter light	12V 60W/55W 12V 5W/21W 12V 21W x 4 12V 4W 12V 3 4W x 2
Indicator light wattage/Quantity "NEUTRAL" "HIGH BEAM" "TURN"	12V 3.4W 12V 3 4W 12V 3.4W x 1



YAMAHA MOTOR CO.,LTD.

IWATA JAPAN

PRINTED IN JAPAN

85 • 12 - 03 x 1 CR

(英)

SRX600 WIRING DIAGRAM

DIAGRAMA ELECTRICO DE LA SRX600

COLOR CODE CODIGO DE COLOR

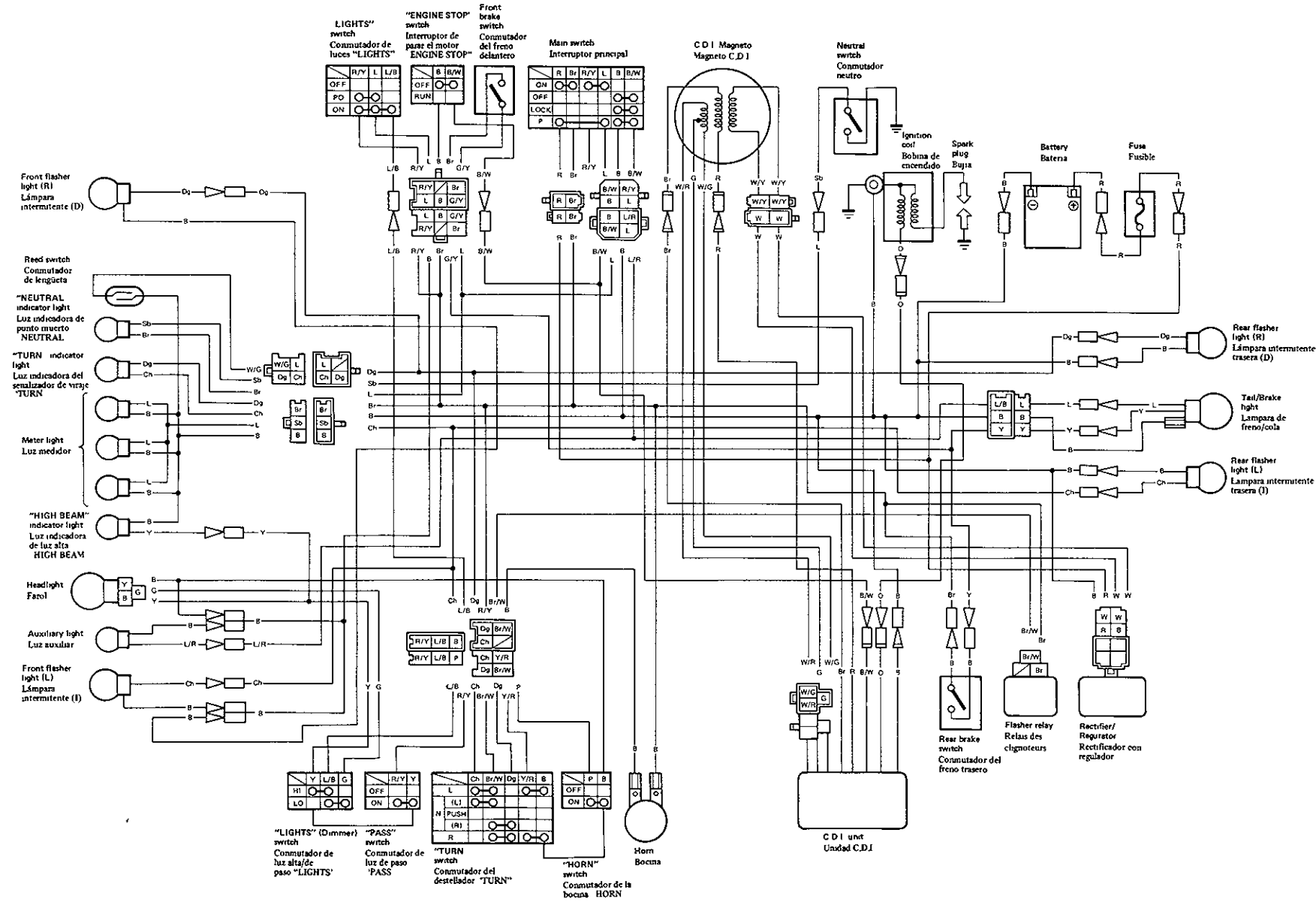

B	Black Negro
R	Red Rojo
L	Blue Azul
G	Green Verde
Dg	Dark green Verde oscuro
Sb	Sky blue Celeste
Br	Brown Marrón
O	Orange Amaranjado
Y	Yellow Amarillo
Ch	Chocolate Chocolate
P	Pink Rosado
W	White Blanco
B/W	Black/White Negro/Blanco
R/Y	Red/Yellow Rojo/Amarillo
L/B	Blue/Black Azul/Negro
L/R	Blue/Red Azul/Rojo
G/Y	Green/Yellow Verde/Amarillo
Br/W	Brown/White Marrón/Blanco
Y/B	Yellow/Black Amarillo/Negro
Y/R	Yellow/Red Amarillo/Rojo
W/R	White/Red Blanco/Rojo
W/G	White/Green Blanco/Verde
W/Y	White/Yellow Blanco/Amarillo

REGISTRO DE LOS NUMEROS DE IDENTIFICACION

1. NUMERO DE LLAVE:

2. NUMERO DEL CHASIS Y NUMERO
DEL MOTOR:

El número de identificación de la llave está estampado en la misma tal como se ilustra a continuación.
Registre este número en el espacio provisto como referencia para el caso de que usted necesite una nueva llave.

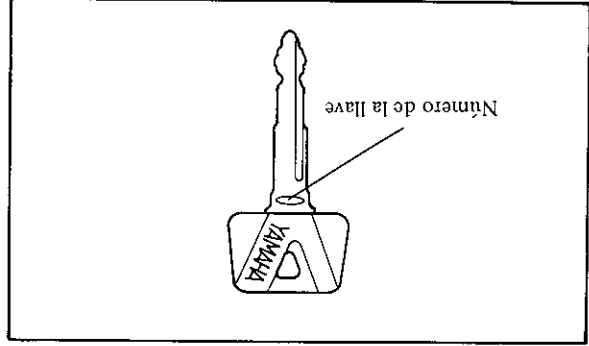

Registre los números del vehículo y del motor en los espacios suministrados para facilitar el pedido de repuestos a su agente Yamaha o para referencia en el caso de que su vehículo sea robado. (Ver la página 2-1)

1XR-28199-WO

MANUAL DEL PROPIETARIO

SRX600

